

MAKE | BUILD | HACK | CREATE

HackSpace

TECHNOLOGY IN YOUR HANDS

hsmag.cc

June 2023

Issue #67

NFC

MAKE PERSONALISED
GREETINGS CARDS

3D

**ULTRASONIC
LIGHTS**

MOTION-DETECTING LIGHTS
FOR YOUR WORKSPACE

Evolution

PRINTING A
LARGE
FORMAT
CAMERA



PRUSA'S
NEWEST PRINTER
ON TEST



We get the
inside story from
Josef Průša

June 2023
Issue #67 £6

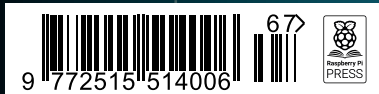

PICO | **CHATGPT** | CATAPULT | **SCOPE**

Free eBook!



Download your copy from
hsmag.cc/freecadbook



Welcome to HackSpace magazine

Does open source matter in 3D printers and, if it does, what should we do to defend it? It's a question that Josef Průša posed to the community alongside the launch of the MK4. Hobbyist 3D printers started with the RepRap movement, where open source was key to a worldwide community being able to rapidly modify and improve designs. We're now in a post-RepRap era when most 3D printer designs aren't open-source (though they might run open-source software).

At HackSpace magazine, we're not open-source purists, and we recognise that commercial reality can make opening your design difficult. However, we view open source as a significant and important feature for users. It means that a machine is easier to modify and fix. It means that the community can continue to update it if the original manufacturer doesn't. It means contributing designs back to the hardware community which helped get us all here. It's with this in mind that we're pleased to feature the Prusa MK4 on the cover this month. This is the latest incarnation in a lineage that has probably done more for open-source printing than any other. And it's a corker.

BEN EVERARD

Editor ben.everard@raspberrypi.com

Got a comment, question, or thought about HackSpace magazine?

get in touch at hsmag.cc/hello

GET IN TOUCH

hackspace@raspberrypi.com

[hackspacemag](#)

[hackspacemag](#)

ONLINE

hsmag.cc



EDITORIAL

Editor

Ben Everard

ben.everard@raspberrypi.com

Features Editor

Andrew Gregory

andrew.gregory@raspberrypi.com

Sub-Editors

David Higgs, Nicola King

DESIGN

Critical Media and Raspberry Pi

criticalmedia.co.uk

Head of Design

Lee Allen

Designers

Sam Ribbits, Olivia Mitchell, Sara Parodi, Jack Willis

Photography

Brian O'Halloran

CONTRIBUTORS

Marc de Vinck, Andrew Lewis, Rob Miles, Jo Hinchliffe, Nicola King

PUBLISHING

Publishing Director

Brian Jepson

brian.jepson@raspberrypi.com

Advertising

Charlie Milligan

charlotte.milligan@raspberrypi.com

DISTRIBUTION

Seymour Distribution Ltd

2 East Poultry Ave,

London EC1A 9PT

+44 (0)207 429 4000

SUBSCRIPTIONS

Unit 6, The Enterprise Centre, Kelvin Lane, Manor Royal, Crawley, West Sussex, RH10 9PE

To subscribe

01293 312189

hsmag.cc/subscribe

Subscription queries

hackspace@subscriptionhelpline.co.uk



This magazine is printed on paper sourced from sustainable forests. The printer operates an environmental management system which has been assessed as conforming to ISO 14001.

HackSpace magazine is published by Raspberry Pi Ltd, Maurice Wilkes Building, St. John's Innovation Park, Cowley Road, Cambridge, CB4 0DS. The publisher, editor, and contributors accept no responsibility in respect of any omissions or errors relating to goods, products or services referred to or advertised. Except where otherwise noted, content in this magazine is licensed under a Creative Commons Attribution-NonCommercial-ShareAlike 3.0 Unported (CC BY-NC-SA 3.0). ISSN: 2515-5148.

Contents

70

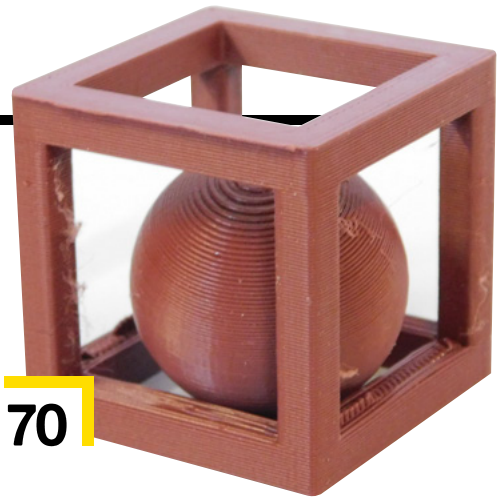

06

SPARK

- 06 **Top Projects**
Clever stuff made by clever earthlings
- 16 **Objet 3d'art**
An affordable family car, for tiny people
- 18 **Letters**
Praise for the brave cat wrangler

21

LENS

- 22 **3D Evolution**
Take a deep dive into the Prusa MK4
- 34 **How I Made: Large Format Camera**
Homemade digital daguerreotypes
- 40 **Interview: Josef Průša**
He's quite pleased with the Prusa MK4. Here's why...
- 48 **In the workshop**
Chain devices together with I2C

Cover Feature



22

Tutorial

Ultrasonic lights



72

Add a cyberpunk feel to your workbench with NeoPixels

14





34

Tutorial

Electric scooter



78

Force captive electrons to do your bidding

53

FORGE

54

SoM KiCad

Go from design to schematic on your first PCB

60

Tutorial NFC

Make custom greetings cards with funky electronics

66

Tutorial Beginning electronics

Go back to basics with a breadboard and LED

70

Tutorial Print in place

Print complex parts in one go

72

Tutorial Ultrasonic lights

A hands-free lighting solution for your workspace

78

Tutorial Scooter part 2

Build a battery pack fit for a king

82

Tutorial ChatGPT

Can artificial intelligence design a robot chassis?



88

Interview

Josef Průša



40

The Willy Wonka of 3D printing talks us through the magic

87

FIELD TEST

88

Best of Breed

Summer is on its way – get outside!

94

Review Pico oscilloscope

Make waves with open hardware

96

Crowdfunding Hoverboard

Float like a 500lb butterfly

Some of the tools and techniques shown in HackSpace Magazine are dangerous unless used with skill, experience and appropriate personal protection equipment. While we attempt to guide the reader, ultimately you are responsible for your own safety and understanding the limits of yourself and your equipment. HackSpace Magazine is intended for an adult audience and some projects may be dangerous for children. Raspberry Pi Ltd does not accept responsibility for any injuries, damage to equipment, or costs incurred from projects, tutorials or suggestions in HackSpace Magazine. Laws and regulations covering many of the topics in HackSpace Magazine are different between countries, and are always subject to change. You are responsible for understanding the requirements in your jurisdiction and ensuring that you comply with them. Some manufacturers place limits on the use of their hardware which some projects or suggestions in HackSpace Magazine may go beyond. It is your responsibility to understand the manufacturer's limits. HackSpace magazine is published monthly by Raspberry Pi Ltd, Maurice Wilkes Building, St. John's Innovation Park, Cowley Road, Cambridge, CB4 0DS, United Kingdom. Publishers Service Associates, 2406 Reach Road, Williamsport, PA, 17701, is the mailing agent for copies distributed in the US and Canada. Application to mail at Periodicals prices is pending at Williamsport, PA. Postmaster please send address changes to HackSpace magazine c/o Publishers Service Associates, 2406 Reach Road, Williamsport, PA, 17701.

ESP32-powered plant monitor

By Ovidiu

hsmag.cc/ESP32-PlantMonitor

We've seen plant monitors many times before now, but this one, by self-taught electronics tinkerer Ovidiu, is worth a closer look.

First of all because its creator is self-taught: if you can imagine it, you can build it; the only downside of being self-taught is that it'll probably take you longer than it would if you knew what to do/where to look.

Ovidiu's used an ESP32 and an e-ink display to create a plant monitor with an impressive eleven days battery life (longer if you run it without the display), and kept electronic components off the soil probes so that they are cheap to replace should they break/get stolen by foxes. The machine monitors temperature, soil moisture levels, humidity, light levels and more, and shares data via Wi-Fi or Bluetooth. ▣

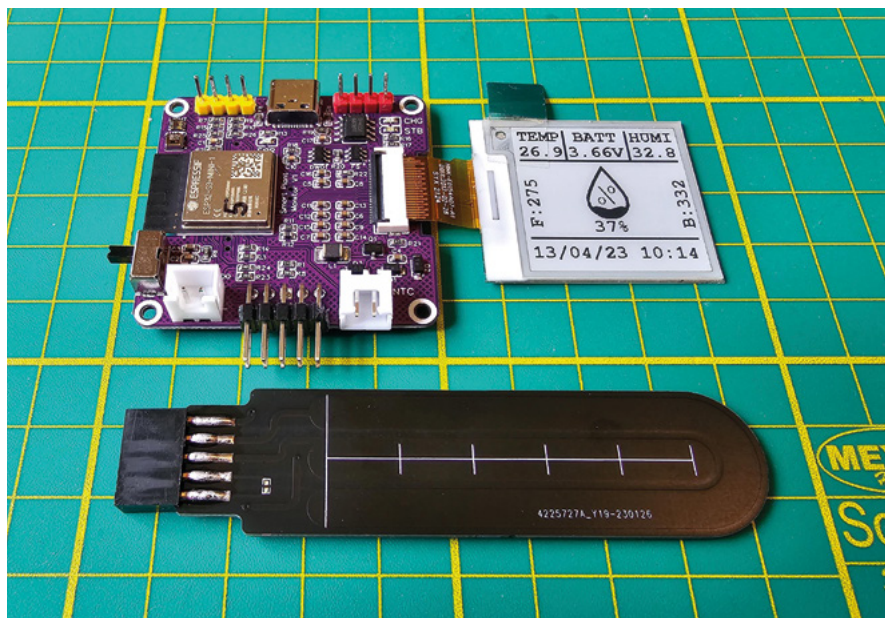

Right ▣
Big respect to all the self-taught hardware makers out there!

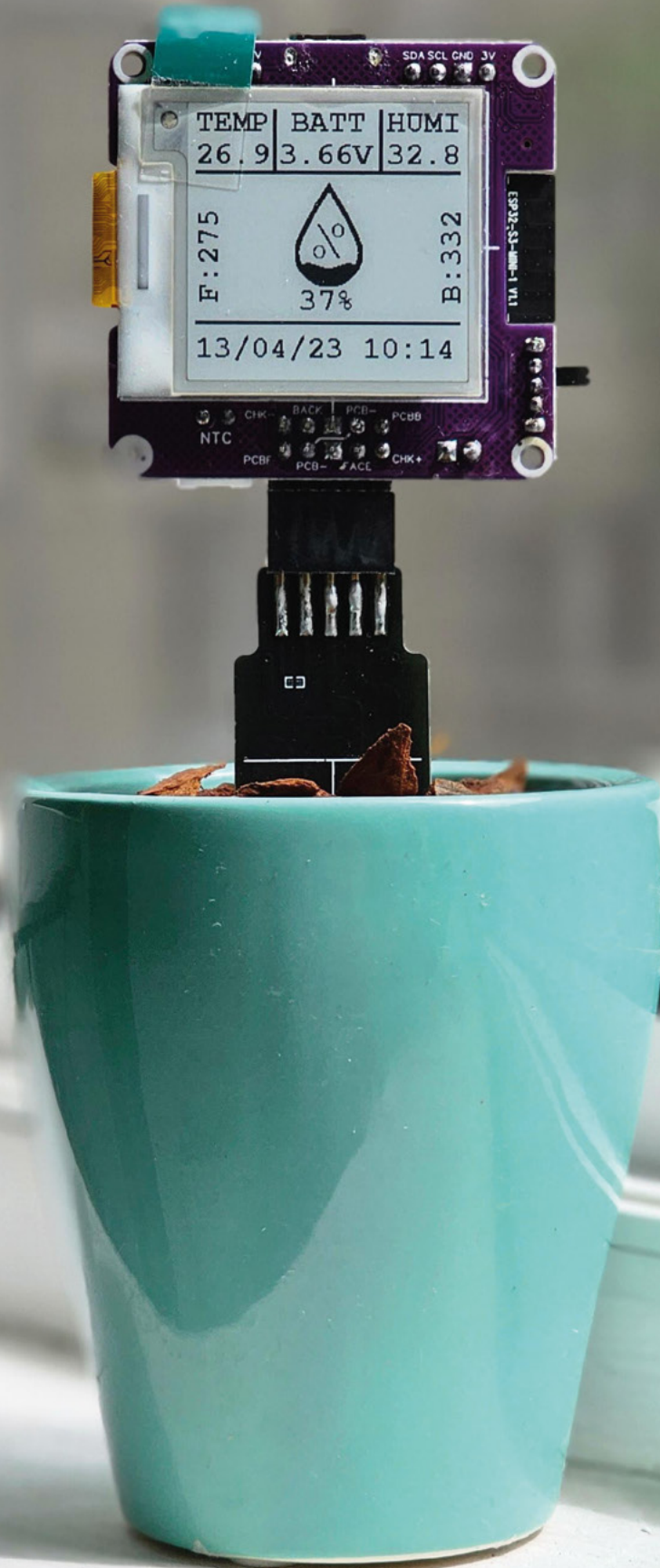

Lego sewing machine

By The Brick Wall

hsmag.cc/LegoSewingMachine

W

e take our collective hat off to anyone who can sew: by hand, it's fiddly, slow, and frustratingly difficult; with a sewing machine it's even harder, as the mechanisation element only means that we can go wrong more quickly. So, we're

extremely impressed by The Brick Wall's sewing machine build, which uses Lego (plus one small rotating handmade part to hook and release the thread) to assemble a working, hand-powered sewing machine. And yes, it produces a perfect chain stitch. □

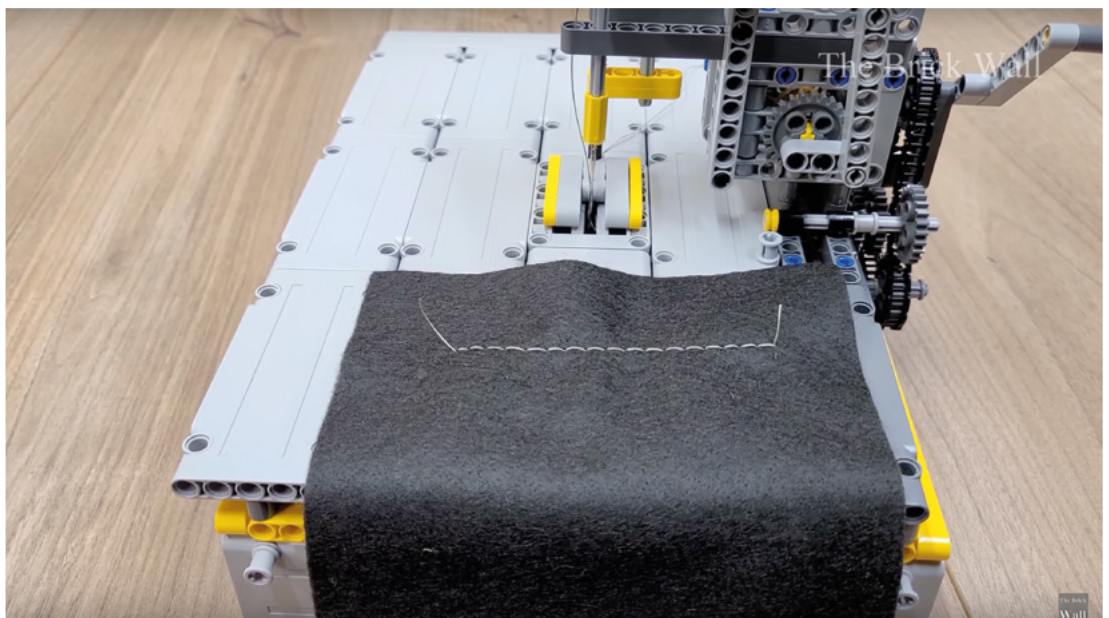

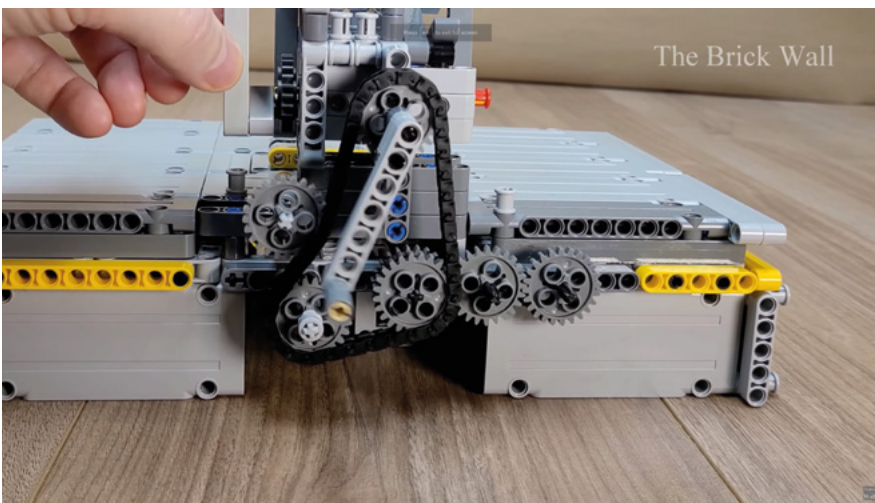
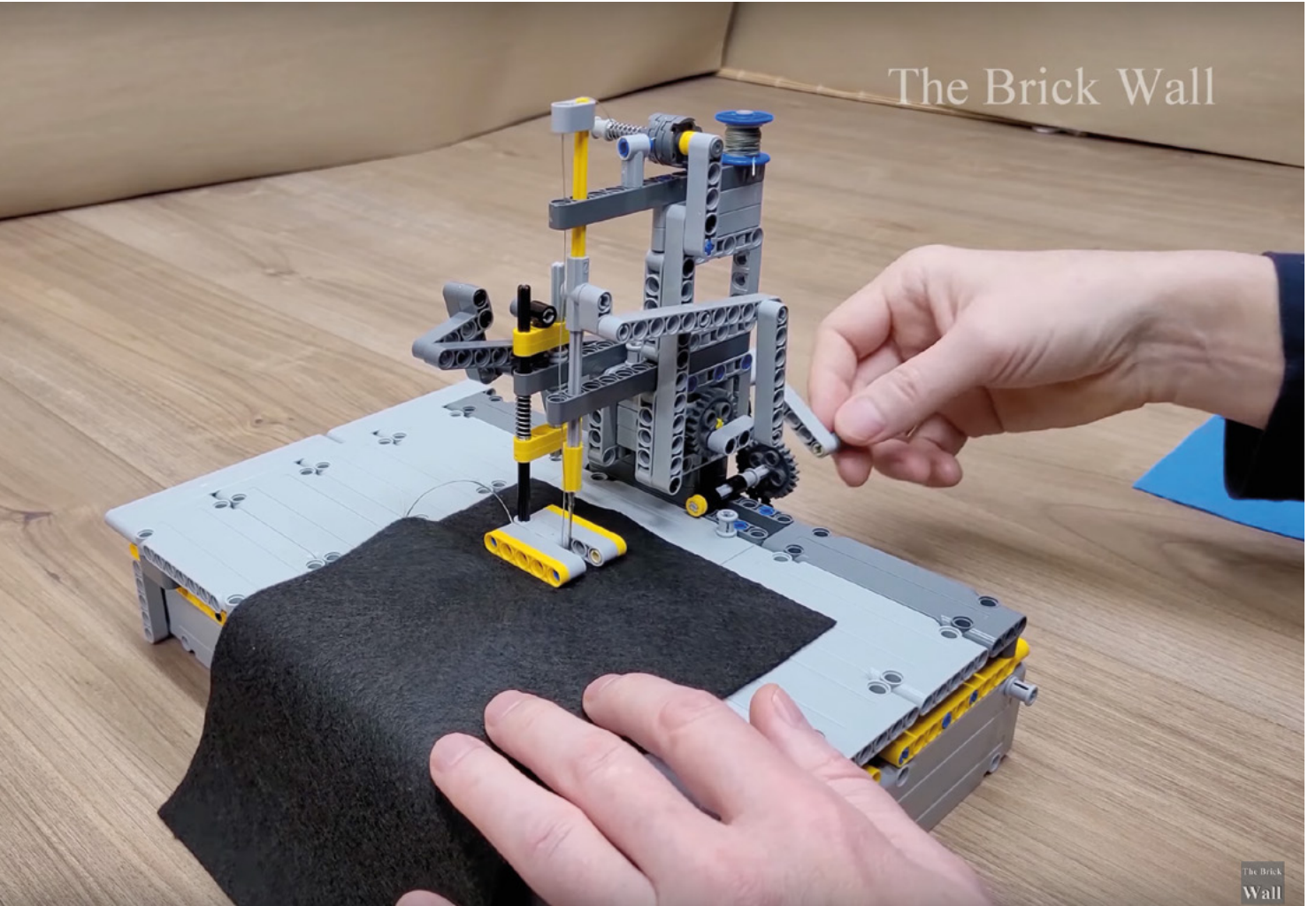

Above  This Lego sewing machine was inspired by the Singer model 20, which was first produced in 1910

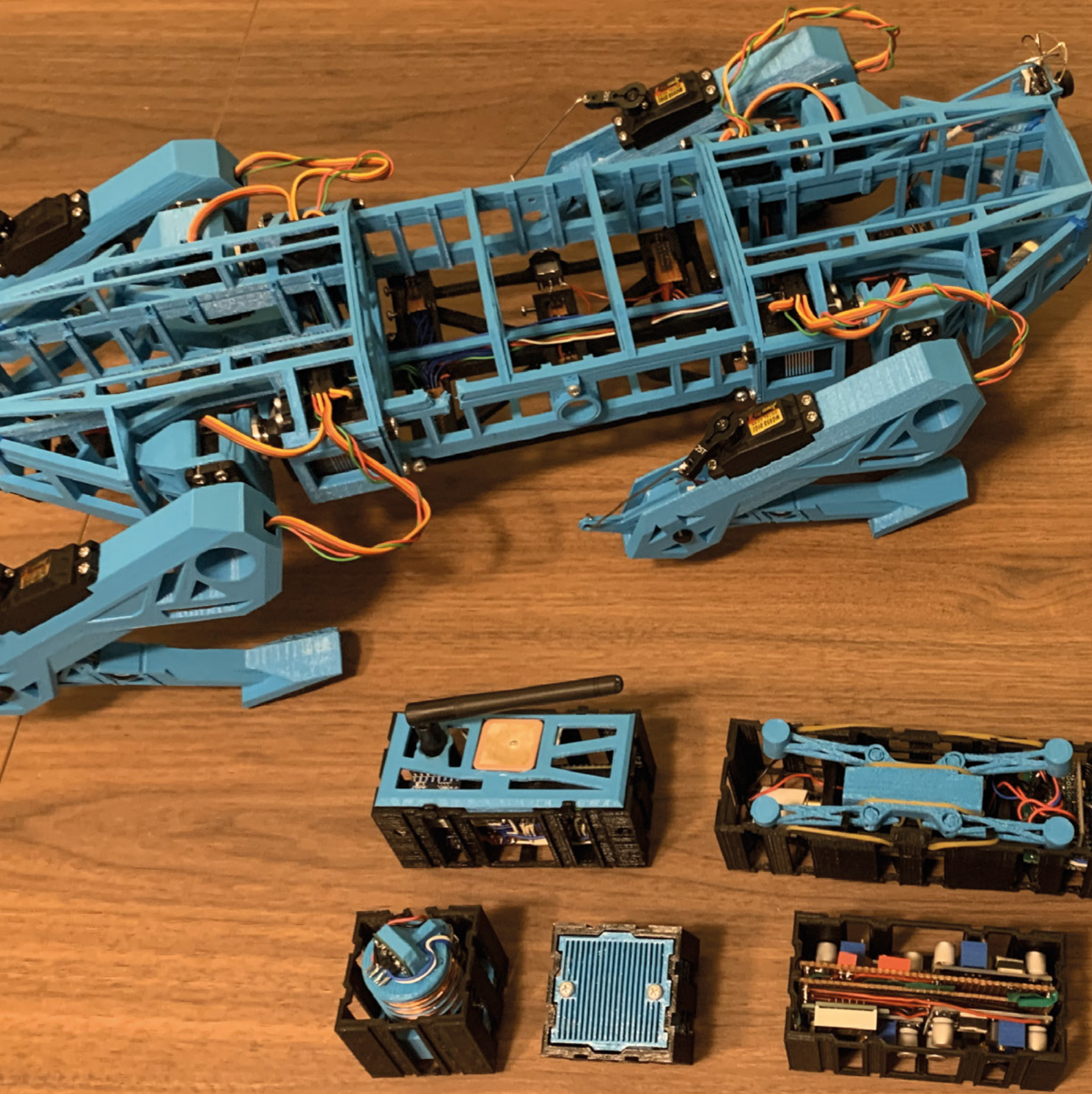

Open-source robot dog

By Halid Yildirim

hsmag.cc/PicoRobotDog

We've seen a few robot dogs over the years, most notably James Bruton's openDog and Boston Dynamics' terrifying Spot hunter killer. Here's one with a twist, created by computer engineering student Halid Yildirim. Halid's big breakthrough has been to separate the electronics from the robot chassis, enabling different electronics modules to be swapped in and out.

Because it's modular, there are key features, and non-key features that can be added or removed to keep the cost down. Core features include the computing unit, battery and power management units, remote control, GPS, gyroscope, and pressure sensors on the legs. Swappable capabilities include Lidar and gas detection modules. □

Left □
Halid's robot is programmed in the Arduino programming language

Furby Borges

By Roni Bandini

hsmag.cc/FurbyBorges

In 2018, Roni Bandini hacked a Furby to turn it into a **Jorge Luis Borges-quoting animatronic**. He left as many components in situ as possible, only bypassing the audio, to create an effect that worked, but wasn't as good as it could have been.

Five years later, the JL Borges Furby is reborn. Roni has removed the original electronics that controlled the Furby's mouth and eyes, opting to replace them with an Arduino Nano and an H-bridge. He's got rid of the original sound effects equipment, replacing it with a DFRobot DFPlayer Mini MP3 player. He's also used a passive infrared sensor, so that whenever someone walks past the furry they're treated to a snippet of the great Argentinian writer's work. ▣

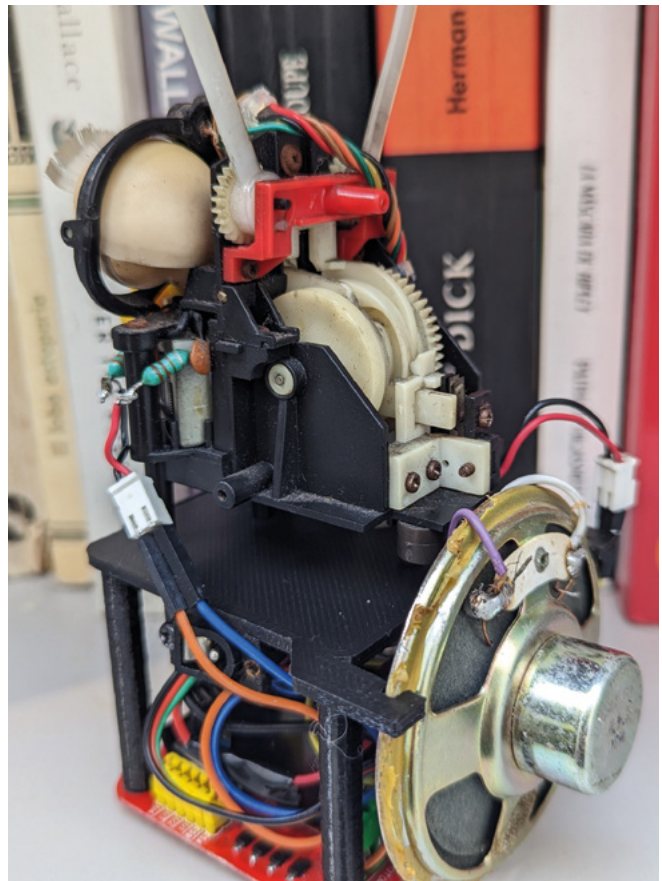

Right ▣
We discovered the works of Argentine writer Jorge Luis Borges when he was quoted in the *Sean Duffy* series of novels by Adrian McKinty. They're very, very good

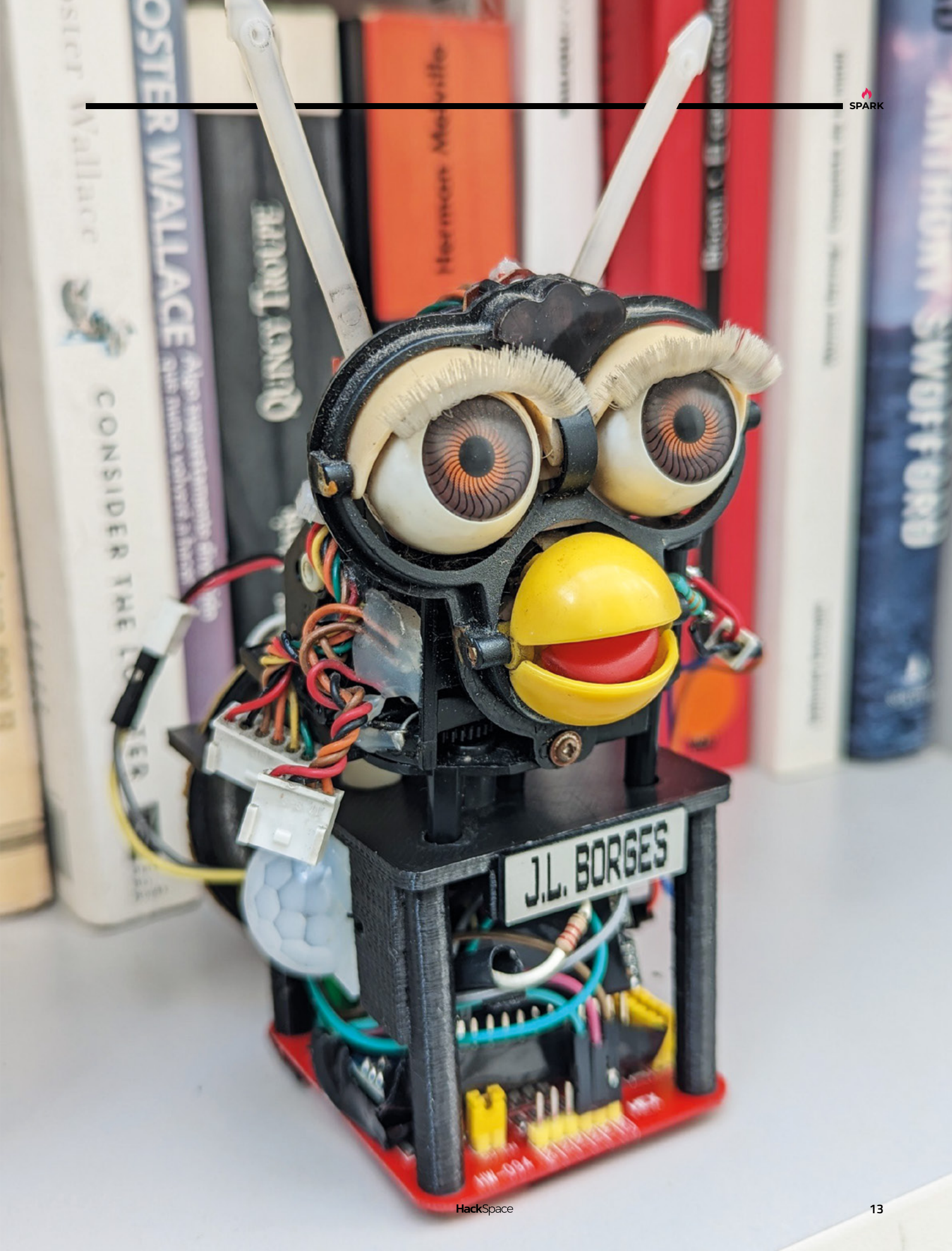



Persist-o-meter

By Yurko Tymchuk

hsmag.cc/Persist-o-meter

Practice makes perfect. But real life gets in the way of practice. To solve the problem of pesky reality intruding onto his valuable ukulele playing time, Yurko Tymchuk has developed a progress tracker using 3D printing and magnets to record his daily goals. It looks a lot like a calendar, and every time you fulfil your goal for that day, you add a magnetised cross to the board indicating success. The text describing the goals is printed on detachable labels, so if you were to get bored with the ukulele and want to learn the piano instead, you'd just print a new label.

This is a 3D-printed model, but with some special instructions: first, it uses 0.2mm layer heights, to get the best fit with the magnets he's used. Second, in order to insert the magnets and to change colours, he had to pause and restart the print a few times. □





Above  Yurko's design uses two 10mm M3 screws and around 50 6 x 3mm magnets

Objet 3d'art

3D-printed artwork to bring more beauty into your life



ccasionally we come across a 3D print that's so well done that we can't tell whether it's 3D-printed or not. That's what

happened the first time we saw this 7.4:1 scale model of a Mitsubishi Pajero, modelled, printed, and assembled by Casadio Design. They've taken their own family car for inspiration, and turned it into a fully functioning radio-controlled, four-wheel-drive model, with results so impressive that, at first glance, we thought those small boulders were the size of large boulders.

Casadio has produced an unbelievably detailed 350-page assembly guide, and you can grab the design files from cults3D.com – see the video at hsmag.cc/Pajero for more instructions. □





Letters

ATTENTION ALL MAKERS!

If you have something you'd like to get off your chest (or even throw a word of praise in our direction), let us know at hsmag.cc/hello

HAXAPHONE

Every so often, an electronic musical instrument comes along that is unique and comes to define a sound. Sometimes these instruments endure to provide an interesting and unique sound through the decades – the theremin springs to mind. Other times they turn out to be a brief spark that illuminates a genre and then dies out – for example, the keytar.

The haxaphone (HackSpace issue 66 page 8) surely fits into one of these two camps – I have absolutely no idea which camp history will place it in. All I know is that I want one!

Brian

Cambridge

Ben says: I am no musician, but I also want to try a haxaphone. I doubt I can get a sensible noise out of the thing, but I'd love to try.

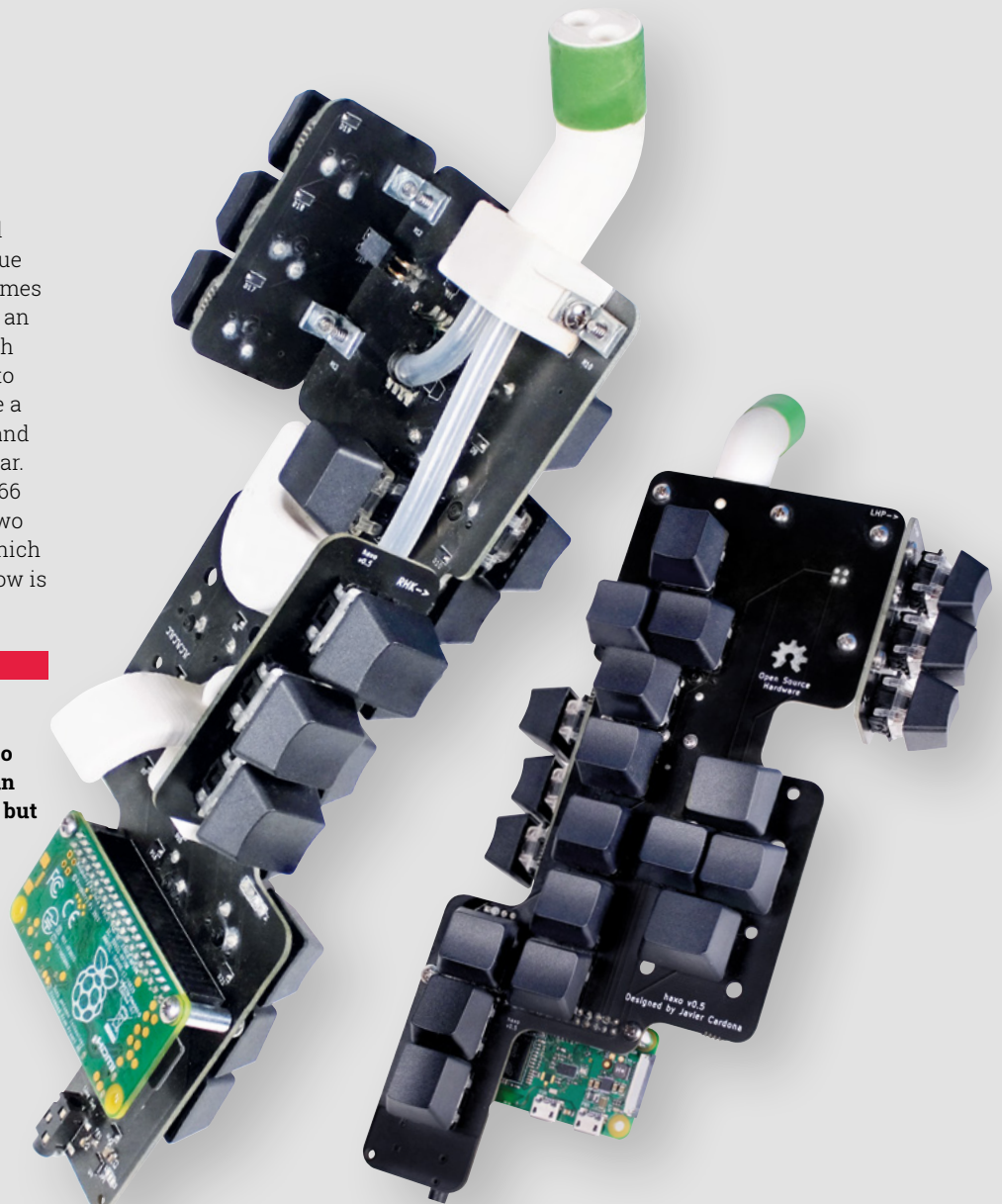



CUTE KITTY

Kudos to Sahas Chitlange. Not only have they created a great-looking build, but they've also managed to acquire a cat patient enough to wear it. I once tried to get my cat to wear a collar, but he spent the entire day gaining the flexibility he needed to rip it off. Since then, anything that's gone near his head has been removed with haste (including an ill-advised 'Evil Unicorn Horn for Cats').

Sandra
Gloucester

Ben says: I too have a moggie that cares little about what I want to do. I'm pretty sure he spends most of his time plotting against me. I hate to think what he'd do if I gave him the power of technology.

SOLDERING SOLIDARITY

Thanks for the tips on soldering with paste in issue 66. I've been through-hole soldering for more years than I care to count, but I'd never tried anything more intricate. We've got a hotplate at my local hackerspace, so I didn't need much equipment. I don't know what I was waiting for! It's actually easier this way. A dollop of paste, pop the component on top, apply heat and Bob's your mother's brother, as they say. Thanks for giving me the motivation to try it.

George
Liverpool

Ben says: You're welcome. It depends a lot on what you want to do really. If you're designing your own boards, I think we've reached a point now where it's easier to go surface mount. The chances are you'll need some components that are only available surface-mount anyway, so you might as well do the lot. It does take a bit more equipment to get started, but not huge amounts, and as you say, there are plenty of community spaces with the bits you need.

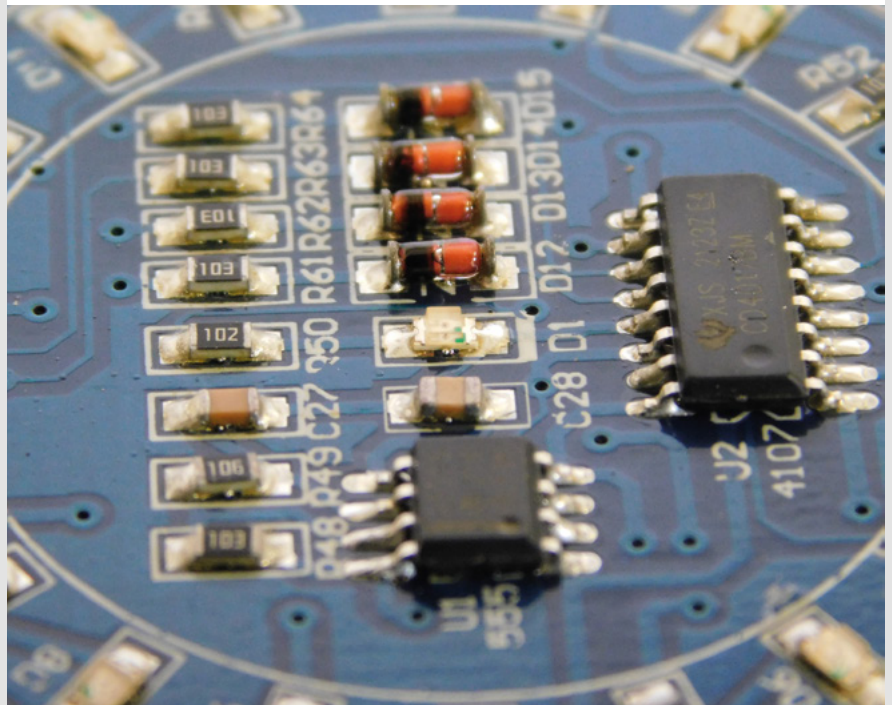

SELECTION STARTS HERE



With over 2,300 name-brand, industry-leading suppliers—be confident we've got your electronic component and automation needs covered.

Find it at digikey.co.uk today, or call 0800 587 0991.



Digi-Key is a franchised distributor for all supplier partners. New products added daily. Digi-Key and Digi-Key Electronics are registered trademarks of Digi-Key Electronics in the U.S. and other countries. © 2023 Digi-Key Electronics, 701 Brooks Ave. South, Thief River Falls, MN 56701, USA

 ECIA MEMBER
Supporting The Authorized Channel

LENS

HACK | MAKE | BUILD | CREATE

Uncover the technology that's powering the future

PG
34



HOW I MADE: LARGE FORMAT CAMERA

Take pictures the way the Victorians did – with a 3D-printed large format camera

PG
40



INTERVIEW: JOSEF PRŮŠA

On development, X-ray machines, and why he's still 3D printing 3D printers

PG
48

IN THE WORKSHOP

We've not managed to build much this month, but we did learn about I2C

PG
22

3D EVOLUTION

PRUSA'S LATEST PRINTER
ON TEST

3D EVOLUTION

PRUSA'S NEWEST PRINTER ON TEST

The Prusa i3 line of printers has its origins at the very start of the hobbyist 3D printer movement. The Prusa Mendel (the first printer to bear the 'Prusa' name), released in

2010 with a blog post that started:

"Hello, I'm new here so I guess I should introduce myself first. My name is Josef Prusa, I'm a 20-year-old student from Prague, Czech Republic and I'm in [the] RepRap world for about a year now. You can follow me on twitter.com/prusajr. Two months ago, I started [the] process of simplifying Mendel design. So far, I was able to reduce parts count, assembly time, use of vitamins, and also price."

The Prusa Mendel evolved to become the Prusa Mendel iteration 2, then the iteration 3 (known as the i3), MK2, MK3, MK3S, and now the MK4. It's the seventh

model in the last 13 years. Some parts have changed. Originally, the Mendel was made of just 3D-printed parts, and off-the-shelf 'vitamins', such as lead screws and bushings. Now, the MK4 still has many 3D-printed parts, but its frame is custom-designed and cast from aluminium alloy. Other things have stubbornly stayed the same, including the iconic 'bed slinger' design, where the Y-axis is the print bed moving back and forth.

The MK4 is on sale now for £1054.80 fully assembled or £790.80 as a kit, and upgrades from the MK3 start at £241. Of course, the obvious question about a printer with such a long lineage is – is it a dinosaur from another era that has been surpassed by modern machines, or does 13 years of refinement mean that this is the ultimate tried and tested machine? We've been investigating. →

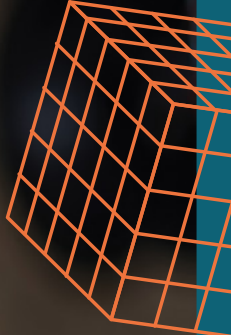
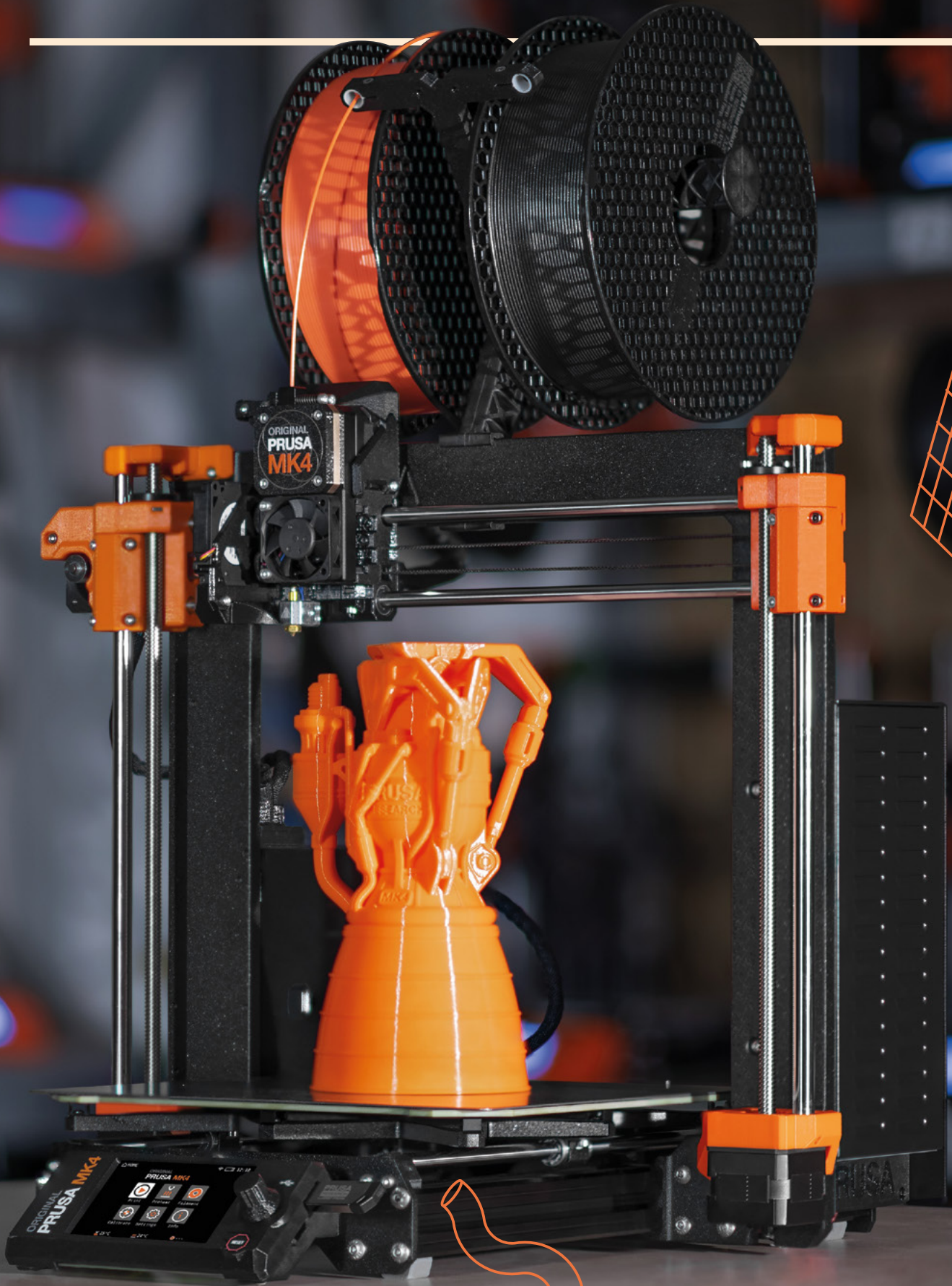

MK4 ON TEST

WHAT'S IT LIKE TO USE THE NEW PRINTER?

At first glance, the MK4 looks much the same as the MK3. It's got the now familiar arch of black aluminium alloy as a frame over the top of a bed that moves in the Y-axis. At the front, an angled screen provides user feedback, and the whole lot is controlled by a single knob and button.

However, while things on the surface may look similar, almost every aspect of this machine has been reworked. In some cases, this is to make it faster, in some cases more reliable and, in some cases, more user-friendly. Let's take a look at what these changes are, and whether they've worked.

When it comes to speed with 3D printers, weight is a huge issue. Not the total weight of the printer, but the weight of the moving parts. There are a couple of things here that are working against the MK4. Firstly, it's a 'bed slinger' design where the

entire print bed moves backwards and forwards as the Y-axis. The print bed is a pretty heavy part of the design. Secondly, it has a 'direct drive' extruder where the motor driving the filament is on the print head itself.

There are advantages to both of these design choices, but they come at the cost of having a lot of mass that the motors have to shift. The problem with this isn't the top speed these axes can achieve, but the amount of momentum that they have when you try to change speed or direction. This momentum can cause the printer to wobble slightly at sharp corners and this becomes visible as wave-like structures on the printed part, known as 'ringing'. You can see this in prints on the MK4.

There is a solution to this, or at least a partial one: input shaping. The idea behind this is that if you can predict where the problems will happen, you can put in additional motor movements to counteract them in exactly the same way active noise-cancelling headphones work. This, however, requires the printer to be able to predict the exact movements caused by the momentum. The MK4, unlike its predecessors, comes with a processor powerful enough to do exactly this.

Bottom right ■
The new larger drive gear has more contact with the filament

JOSEF PRŮŠA

HackSpace Magazine: *The Prusa MK4 is an incremental design. You've been working on that for a number of years, right?*

Josef Průša: Definitely. As with any product, even when you are pushing a product to the market, you already know what you want to improve in the next versions. How long does it take to finalise a product? It might take half a year, or more, to [get] a finished prototype into production. So, we've been developing some of this stuff since very soon after releasing MK3.

HS: *And in contrast to that, the XL is an all-new design. Has that resulted in a big difference between the two new models?*

JP: No, I would say not really. Most of the time they were being developed concurrently. As we were developing the new system for the electronics and the new firmware for this generation of printers, we just added XL on top of that, and the features for the tool changing were added. But the printers themselves are completely different machines. I would say MK4 is the everyday workhorse that you have at home or in the office, whereas the XL is exploring what can be done: with multi-material printing, with the tool changer, it's just made to experiment with new stuff.

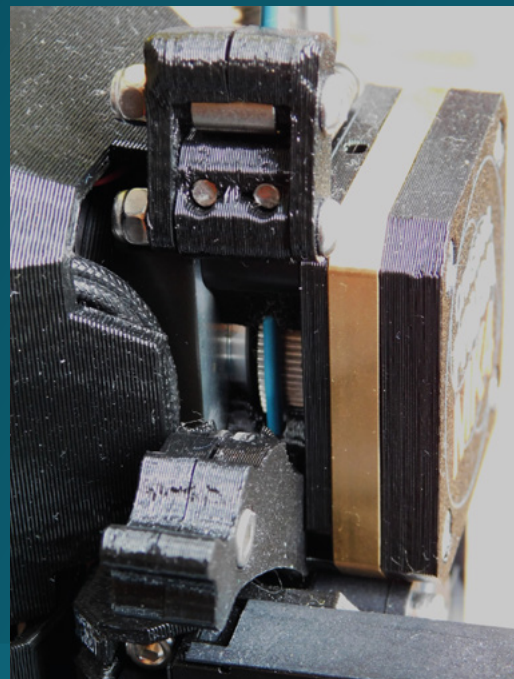



Left ◆ All the power and signals from the extruder are combined into a single cable

Below ◆ Two screws tension the idler gears, but can be released with a catch

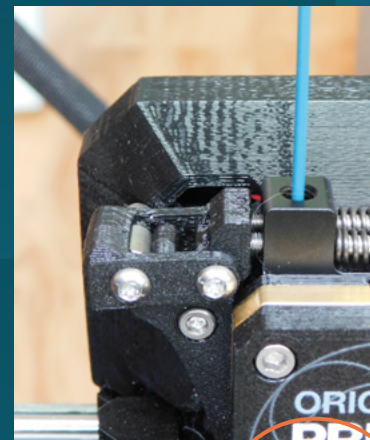

“Prusa has promised a pre-release version of the firmware”

Alongside input shaping, there’s also pressure advance, which is another way of calculating the difference between the ideal world of G-code and the real world of kinematics, except this time for how the extruder pushes out plastic. When the extruder first starts extruding a line, there’s a short delay before plastic comes out and, likewise, when it finishes, there’s a delay between the extruder stopping and plastic stopping squirting. At high print speeds, this can cause problems, so to print reliably, the printer needs to be able to compensate for this.

At the time of writing, the Prusa MK4 had the hardware to do input shaping and pressure advance, but it wasn’t supported by firmware. Prusa has promised a pre-release version of the firmware supporting these features in the very near future (indeed, it may have shipped by the time you read this), with a stable release in due course. While the promotional videos that they’ve released showing this running look impressive, we haven’t been able to test it out.

Without input shaping and pressure advance, the MK4 is a moderately fast printer; certainly faster than any of the previous generation of bed-slinger printers that we’ve come across. There is a bit of ringing at points with sharp corners, but it’s not particularly noticeable unless you’re looking for it. However, it’s slow compared to the latest crop of fast printers (which are mostly CoreXY designs where the print bed moves in the Z-axis).

PRINTING HEAD ON

The new extruder – branded the Nextruder – is probably the flagship feature of the new printer. It’s lighter than previous iterations and the weight is now closer to the X-axis, meaning that it can be controlled more closely at higher accelerations. While speed is an important factor, perhaps the →

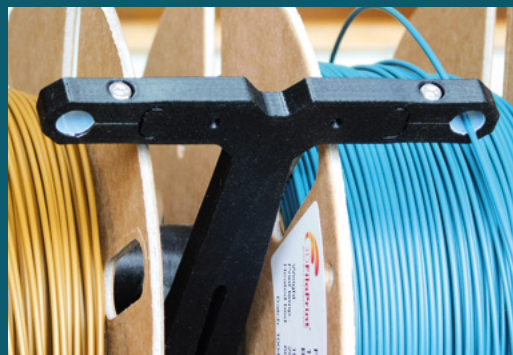

Left ◆ A new filament guide keeps the filament on the spool, even when the extruder is moving around quickly

MOTOR MAGIC

The previous MK3S incarnation of this printer had motors with 1.8 degrees per step, and these have been upgraded to 0.9 degrees per step. These can resolve a higher degree of accuracy and create smooth prints. Prusa calls the difference 'Vertical Fine Articat' or VFA. The result is noticeable, but not enormous. If you're producing prints that have to be absolutely top quality, then this might reduce the amount of sanding and filling you need to use.

biggest change here is the inclusion of a load cell. This component acts much like a set of electric scales, only upside down, and allows the printer to monitor the force on the nozzle. At present, this is used to calibrate the mesh bed levelling. By detecting the actual distance from the nozzle to the bed, this printer eliminates the need for first-layer calibration, even after nozzle changes or print surface changes. This should mean that the first layer prints correctly every time, regardless of what changes you make to the printing setup. There's no more first-layer calibration, no live adjust z. You can swap print surfaces, swap nozzles, rebuild the print head, and the MK4 adjusts everything automatically. At least, that's what Prusa claims, and in our tests, it works. No matter what we've done to change the setup, the first layer has always come out clean.

There's also been a change in the way the extruder motor pushes the plastic out. In previous versions, the filament has been forced between two small gears, but in the new setup, there's a single, larger drive gear (and two smaller idler gears). The claim is that this should make it more reliable. So far in our testing, this has proved reliable, but the true test of this will be in the years to come.

Below the extruder motor, the filament is forced through the hot end. Here, perhaps, we see the biggest change to the printer, although it's completely invisible at a casual glance.



Above ♦ The grandly titled 'love board' sits on the extruder, and lets you disconnect any of the electronic parts with a simple quick-release socket

The previous V6 nozzle assembly has been around for a long time – and does the job well. Nozzles are cheap and available in a lot of different forms. However, it also has drawbacks, not least the fact that the whole assembly is a little complex. The nozzle screws into the heat block. Above this, a heat break helps stop the temperature creeping up into the extruder. However, this heat break was lined with PTFE which breaks down at 230 degrees. There were three parts that had to come together perfectly and if they didn't, either the filament got a bit stuck or oozed out around the side.

Below the extruder motor, the filament is forced through the hot end"

In the MK4, the nozzle comes attached to a metal tube which screws into the heat break. This metal tube pushes into the extruder and the aluminium body of the extruder acts as a cooler. There are a couple of advantages to this. Firstly, a simpler filament path generally means fewer problems and, secondly, it's much simpler to remove the assembly – two thumbscrews bring everything out.

You can then very quickly swap in a new hot end assembly with, for example, a different nozzle size. You can do this very quickly if you have the whole assembly ready to go (that includes heater, heater block, and thermistor). Alternatively, you can unscrew the nozzle (including the tube) from the heater block and it's a slightly slower process.



Below ♦ The MK4 has the same dimensions as the MK3, so fits in the same enclosures

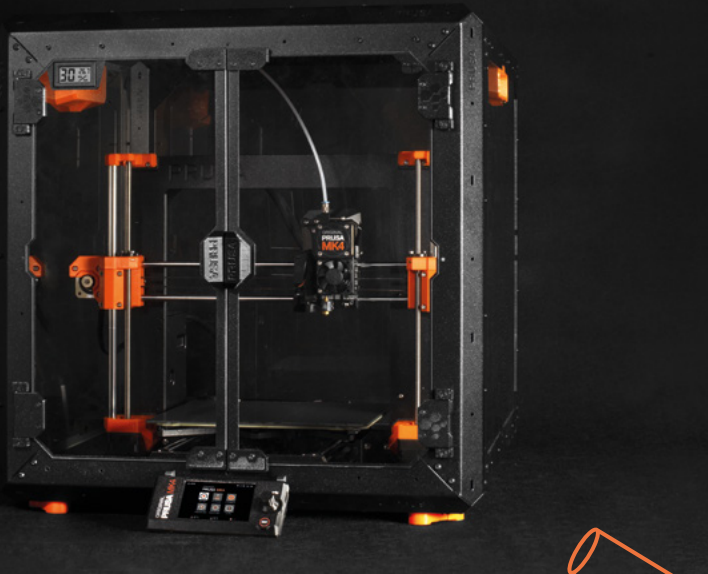

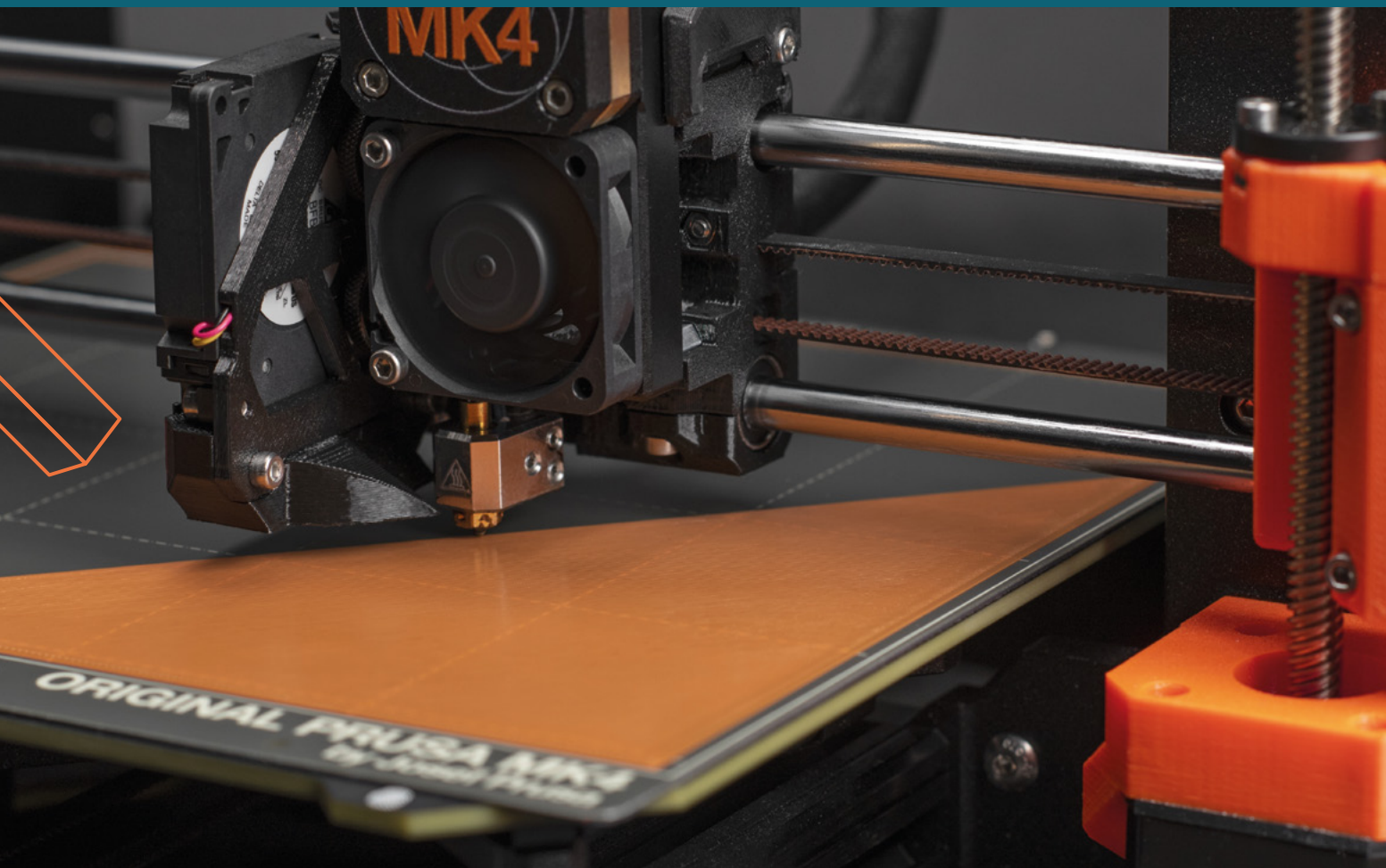

The thermistor, in particular, has thin wires and very little strain relief, so could be a weak point here if you plan on swapping the nozzle a lot.

Having spent more time than he cares to remember with one of the older extruders in pieces, this reviewer is very glad to see everything simplified. Another new addition – the love board – also helps keep disassembly simple. This board combines the signals and power from everything in the extruder and makes it simple to unplug any of the electrical components.

The downside of changing away from the classic V6 nozzle is that you no longer have access to the huge range of nozzles that are available in this format. You can get a V6 adaptor for the MK4 to let you use any that you already have, and Prusa has promised a wider range of nozzles will be available shortly, but we can't currently say what will be available.

One bugbear of the MK3 with this reviewer was the screw that tensioned the extruder gears. There's no way of telling if it's tightened sufficiently. If you have to undo it (for maintenance), you just tension it until it feels about right and then hope that it doesn't start grinding the filament. On the new extruder, there's a clip to release the tension. While there's still a screw to adjust the tension, you don't need to unscrew this to perform maintenance on the printers. It's a little change that is easy to miss, but one that will make a few lives easier. →

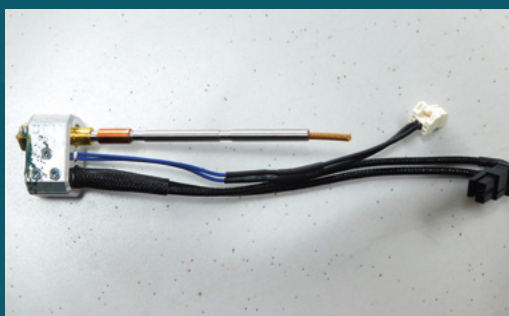

Above ♦
The load cell produces a great first layer with no tweaking

Left ♦
The whole hot end assembly that can be removed with just two thumbscrews

UPGRADE OPTIONS

You can upgrade earlier Prusa printers with some of the features of an MK4. The options are:

- **MK3.5:** This upgrades the electronics of a MK3S (or MK3S+) to those of an MK4. Once Input Shaping and Pressure Advance are available, this should support it.
- **MK3.9:** This builds on the MK3.5 upgrade to also include a Nextruder. This brings load cell bed levelling, quick-swap nozzles, and the rest of the advantages of the new extruder.
- **Full MK4 upgrade:** This includes everything of the MK3.9 and also upgrades the motors to the high-precision ones.

These are all available as upgrade kits. You'll need to print some of the parts, but filament is included in the kit.

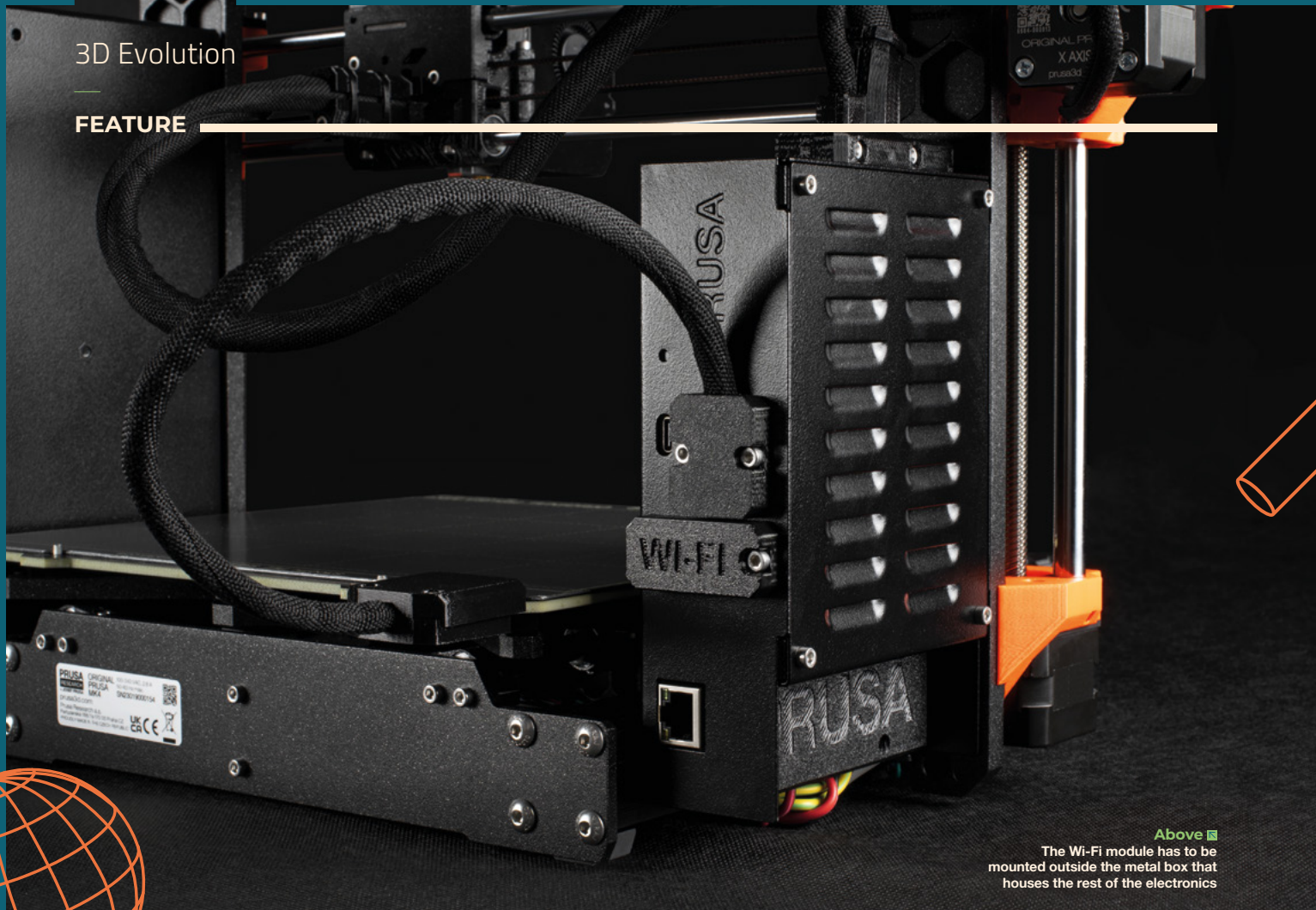

Above  The Wi-Fi module has to be mounted outside the metal box that houses the rest of the electronics

JOSEF PRŮŠA

HS: What are your favourite features on the XL and the MK4? Or is that like asking you to pick your favourite child?

Josef Průša: No, I know, for a fact. It is the load cell homing. I recovered my old Flickr account recently; you know, as the company was bought and sold a few times, it got a little bit locked out, but I recovered it. And I found a picture of my very first prototype of the load cell, taken twelve years ago. It's taken that long to get to this point, where I can ship it and be happy with it. I've waited twelve years for this.

I'm sorry that we couldn't be first in the market, due to the pandemic and stuff, but we are not using simple on/off; we are really reading the unknown values and the position.

The load cell is placed in a way that it cannot be damaged inside the all-in-one extruder/ heatsink and it calibrates basically with every tap, so there's no way it can drift over time.

When we were testing it, the key was that we had an egg on the heat bed and we were dropping on top of the egg. The goal was not to break the egg. It's very gentle. And it is the first implementation which got to the people, and I cannot wait to see how we can optimise it further. It's quite cool to see how people have tested it out on the livestreams. They print the first layer, then walk away knowing that the rest of the print will be good. They're printing on balsa wood, on cardboard. I will probably embrace this weirdness a little bit more and include a mode for printing on curved surfaces – something in between non-planar slicing and normal layer slicing. Something in between, because the non-planar slicing is such a difficult problem to generalise and get out the door. But we can optimise quite a lot to print on non-planar surfaces.

With the load cell being part of the nozzle, you are sure that the range is, and the forces are, the same around the whole print volume. But if the sensor is placed somewhere else, it is not quite as consistent, especially if you want to enable printing on some more special materials.

Throughout our testing of the Nextruder, the thing that has stood out is that it's just nicer to use than previous iterations. It's easier to get the first layer correct, it's easier to set up, it's easier to take apart, it's easier to maintain. While having a fast or highly detailed printer is obviously a good thing, having one that works is better. It's hard to quantify how much of an impact these changes will have in the weeks we've been testing this printer, but anything that makes it easier to set up and maintain will undoubtedly have a big impact on how much

Below  This model (by Triple G Workshop on Printables) printed crisply at 0.2mm layer height





Above ♦ You can see the ringing on this model (Whistle Pan flute by dp makes on Printables). Input shaping should help reduce this when it becomes available

use and enjoyment you'll have out of your printer over the years. This is even more important for printers that are used in communal scenarios, whether that's a workplace or makerspace.

A GUI FOR GOOEY PLASTIC

Although the printer retains the classic screen and knob interface, the MK4 now has a higher resolution colour screen. For almost any other piece of tech released in 2023, having a colour screen wouldn't be news, but the i3 line of printers have held onto the monotone LCD for far longer than most.

“The screen is touch-sensitive, but this isn't enabled at present”

According to Prusa, the screen is touch-sensitive, but this isn't enabled at present. We're certainly pleased that they've decided not to use the touchscreen. Twiddly knobs are far easier to use, at least for us.

It's a testament to the interface design that there's relatively little to say about it. Generally, user interfaces are only notable when there's a problem. With the MK4, we've just been able to do what we want to do without thinking too much about the screens that let us do this. There is only one problem with the interface on the MK4 – they have decided to retain the reset button under the knob. This is possibly the most useless button in 3D printing.

The thing that we've long admired about the Prusa line of printers is that they just keep on going. That's not to say they always work – they

don't – but when things go wrong, they're fixable. Our workhorse printer is an MK3S that was once dropped out of a loft (pro-tip, don't hold them by the spool holder). Yes, it broke, but the designs are available, so we could just print replacements for the broken parts and we were running again within a couple of hours. This isn't the only bit that's been replaced on the printer over the years, and the original orange and black colour scheme is turning into a patchwork.

The MK4 seems like an evolutionary upgrade and brings additional ease and speed to this line of printers. At the moment, the big unanswered question is regarding speed. Will it be able to keep up with the fast CoreXY designs that are now available? According to Prusa, it'll be very close to these printers in terms of speed (they've released a video of it printing a Benchy in under 20 minutes with a 0.25 mm layer height and 10% infill), but until the speed features are enabled in the firmware, we can't confirm this – or see what sort of impact this will have on quality.

Even without those sorts of speeds, the MK4 brings the i3 series up to date, and continues the Prusa tradition of making solid machines that are easy to use and produce good prints time and time again. It'll be a reasonable choice for a workhorse printer.

However, if this printer really can print reliably at high speeds, then they'll have shaken up the 3D printer market once again with a high-speed, reliable, and easy-to-use printer at a reasonable price. If their MK3S upgrades can offer a cost-effective way for people to retrofit this fast printing onto existing machines, then this will be even more of an achievement. It is, however, still in the realm of 'if' at the time of writing.

Can Prusa do it? We're poised and ready to test. So, as soon as there's firmware available, we'll let you know. →



Above ♦ The new motors mean that flat parts – like the triangles on this low poly wolf (by Brett Poultney on Printables) – come out much crisper



Left ♦ The colour screen is now accompanied by colour text on the front console

INTERNET OF PRINTERS

PRUSACONNECT AND PRUSALINK

So far, we've looked at the printer hardware, but the MK4 does have one more trick up its sleeve: wireless connectivity. While network connectivity was an optional bolt-on for the MK3, it's built right into the MK4. Internet access on devices can be a bit of a double-edged sword. On the one hand, it can be a useful tool to make the machine more accessible. On the other hand, it can be a way for companies to try to lock users into closed ecosystems. How these two factors play out depends entirely on how the company behind the product decides to develop the software.

Below  You can control the basic printer settings from anywhere in the world

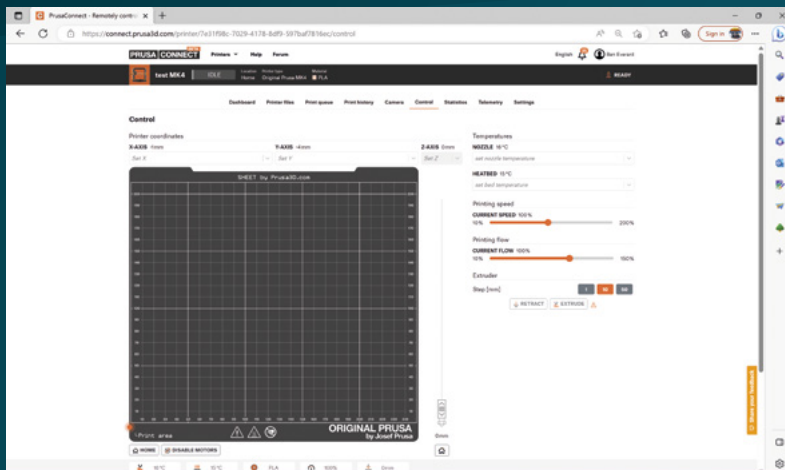

Prusa has two different systems for accessing the MK4 over the network:

- PrusaLink is a way of accessing your printer from the local network. This allows you to forego plugging and unplugging the USB stick (though you will still need one attached to the printer), and just transfer files directly to the printer. You can upload files either through a web interface or by uploading directly from the slicer.
- PrusaConnect is an online service that lets you control your printer from the internet. It has the same features of PrusaLink, plus online file storage and the ability to manage multiple printers. You can upload files, adjust settings and launch prints from any internet-connected device.

OCTOPRINT

While we like PrusaConnect, it's not the only option for adding network connectivity to your MK4. At the time of writing, the OctoPrint setup for the MK4 is still in the early stages, but it will most likely quickly become straightforward to connect.

There are pros and cons to the two systems.

OctoPrint has a huge range of add-ons that can perform almost any action. It's well tried and tested and includes support for webcams and time-lapse photography. Because it streams G-code line-by-line as it prints (rather than transferring files in one go), there's not the lag as the files transfer.

However, it does require additional hardware (a Raspberry Pi). Accessing OctoPrint from the internet (as opposed to the local network) is something that you'll have to set up yourself, either through a cloud service or by managing the routing of a connection from the public internet onto your private network.

Both of these options have been around for a little while, but required you to add additional hardware (a Raspberry Pi). With the new control board, everything runs everything.

You can add a camera to PrusaConnect by repurposing an old phone or tablet. Just install an app and point it at the printer to keep an eye on what's going on.

You can add a camera to PrusaConnect by repurposing an old phone or tablet"

PrusaConnect is officially in Beta, so not ready for prime time. In our experience, the features that are there work well, but it's a bit limited in what it offers. For example, we'd like multiple users to be able to access a printer and track the amount of filament on a spool, but neither of these is available at the moment. If you've got more complex needs, you might want to consider OctoPrint (see box). Obviously, remote access to

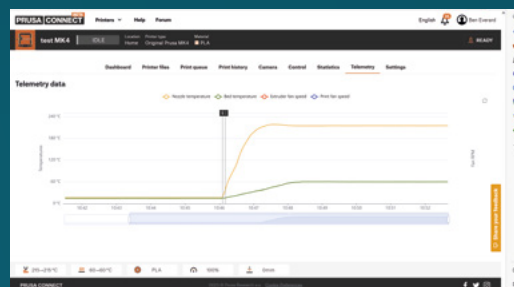

Above You get 2Gb free online storage, and you can also transfer files onto your printer's USB stick

Left You can check on the printer's sensors via the PrusaConnect web page

the printer doesn't mean you don't have to be physically there to remove the prints and prepare the print surface.

The one drawback of these systems is that it's quite slow to transfer data to the printer. Some of the more complex print files took tens of minutes to transfer, so if you're in the same space, a USB stick might be a quicker option.

We appreciate the open nature of the internet connection on the MK4. You can use the bits that make sense to you, whether that's none, local network access, or full cloud control. While it's not the most fully-featured system at the moment, it's really easy to set up and use, and doesn't need any additional software. □

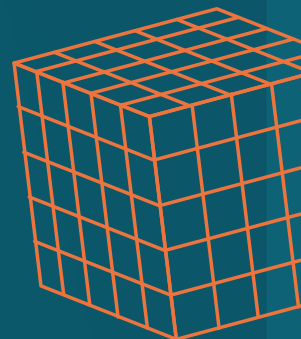

SUBSCRIBE TODAY

FOR JUST £10



Get three issues plus a
FREE Raspberry Pi Pico W
delivered to your door
(UK only)

hsmag.cc/FreePico

Subscription will continue quarterly unless cancelled



NEW



INTERNATIONAL OFFERS!



Get 6 issues plus a **FREE** Raspberry Pi Pico W for just...

\$43 USA / **€43** EU

£40 Rest of the world

Head to hsmag.cc/subscribe to get yours today!

MAKE | BUILD | HACK | CREATE
HackSpace



SAVE 44%

PICO | CHATGPT | CATAPULT | SCOPE

HOW



Modern digital cameras use image processing technology to produce high-quality results. But this makes everyone's pictures

look perfectly identical, and it takes a lot of the satisfaction out of getting a good picture (at least for the author). In this article, you'll discover how to use retro technology and 3D printing to create a super high-quality film camera that gives your photographs a real sense of occasion.

By Rob Miles

I

MADE

HAVE CAMERA, WILL TRAVEL

Figure 1 shows the completed camera. The body is 3D-printed from designs at hsmag.cc/WillTravel. The body was printed in white PLA, which turned out not to be the most lightproof of colours. You should use a darker colour. The camera has since been sprayed with multiple coats of matt black paint – both inside and out, to make it more light-tight. The light proofing is not quite perfect on the author's camera, but this is only a problem if the camera is



PRINT YOURSELF A LARGE FORMAT CAMERA

Create super high-quality images using
a camera you printed yourself

Figure 1

The hand grip on the left contains a cable release which is linked to the shutter on the front of the camera. You can trigger a shot by pressing down the plunger on the handle. This makes it much easier to use. Plus, the author thinks it looks cool

used in direct sunlight. He plans to add some felt inside to improve this. The camera lens at the front is mounted onto a helicoid (the black cylinder with the three knurled rings behind the lens in **Figure 1**) which is turned to move the lens in and out and adjust the camera focus. There are also designs available which use 3D-printed threads on the lens holder to screw the lens in and out.

TO INFINITY AND BEYOND

One of the first things you need to do when you have built your camera is discover the focus position for infinity. Ideally, this would be when the lens is closest to the camera. Then, as you move

the lens further away from the camera, it will focus on closer objects. You identify the infinity position by pointing the camera at a distant object and then adjusting the lens until the image is sharp. You can use this for 'zone focusing', where you just set the lens for the distance the camera is from the subject, and everything in that zone will be sharp. If you look at the camera in **Figure 1**, you will notice some white dots painted on the lens mount. The two you can see identify the infinity focus →

What I used

- A lens and shutter assembly. Search your favourite auction site for 'large format shutter lens'
- Some 4x5 film holders. Search for '4x5 film holders'. You put your unexposed film into them, and they attach to the back of the camera to expose the film. These can be found quite cheaply
- If you are making the helicoid version of the camera, you will need a 'M65 to M65 Mount Lens Adjustable Focusing Helicoid 17–31 mm Macro Tube Adapter'
- 6 × M3 6mm countersunk bolts and 6 × M3 3mm (length) × 5 mm (outer diameter) brass knurled insets
- 3/8" to 1/4" tripod screws adaptors
- If you want to add the viewfinder, search for '2 Functions Mobile Phone Lens 0.45 × Wide Angle Lens and 12.5 × Macro HD Camera Lens' on your favourite shopping site
- A dark 'changing bag'. This is a light-tight bag where you transfer your film into the film holders that are loaded into the camera
- A 4x5 cm ground glass screen. The best place to buy one of these is from Intrepid Camera (intrepidcamera.co.uk). It also sells Fresnel lenses
- A length of elastic 'bungee' cord, as used in jackets and hoodies. This holds the back screen on the camera and stretches to allow you to insert the film holder
- Designs for your camera. You can download them from here: film.kolve.org/3ddesign

KEEPING THE COST DOWN

Photography can be expensive. You can spend a lot on a modern digital camera. But you can have fun and make amazing results for a lot less cash. The most expensive component of the camera is the lens and shutter assembly. This focuses the image and controls the amount of light that reaches the film. These lenses can cost over £100, but the good news is that, unlike the latest digital camera, an old lens will hold its price very well. It might even go up in value. You can swap a single lens between multiple cameras, as they all use the same fitting. Film and developing your photos are getting expensive, but there are some very good low-cost films around, and you can find bargains with expired sell-by dates. Home processing is cheaper and quicker than sending your shots away and is a lot of fun. You can pick up a second hand scanner to get your negatives into your computer, or you can use a smartphone to photograph the negatives and an app to convert them to positive images. For around the cost of a few video games, you can get yourself started on a creative and fun hobby.



Figure 2 You can add a Fresnel lens on top of the ground glass to make the image brighter



position. When the two dots are aligned, the camera is focused on the far distance. There is also a dot for 2m focus distance.

IN THE FRAME

To set up your photograph with the camera, you attach a viewing screen to the back, as shown in **Figure 2**. The screen is held in place with elastic cords. It contains a sheet of ground glass which is placed in the position that the film will be in when the picture is taken. The lens projects an image onto the ground glass. Because of the way lenses work, the image is inverted and flipped left to right, which makes the viewfinder interesting to use, but you do get used to it. The image can be hard to see, especially if you are outside. You can improve your view by putting a 'dark cloth' around the camera and over your head to keep out external light. This also gives your pictures a proper Victorian sense of occasion.

If you are using zone focusing, you can set your focus using marks on the lens and use the round optical viewfinder on the top of the camera to frame your picture. The viewfinder is based on a close-up lens which is sold for use on mobile phones. When you

Right →

The bright parts of the sky have come out completely black, whereas the dark area under the table is white in the negative



are ready to take your shot, you slide a film holder in front of the viewing screen.

WELCOME TO THE DARK SLIDE

The film holder contains a 'dark slide' that protects the film from light. When the holder is on the camera, you remove the dark slide, take the picture (having remembered to set the shutter speed and aperture), and then put the dark slide back into the holder and remove the holder from the camera.

A film holder contains two sheets of film, one on each side. The author owns two film holders, which means he can go out and take four pictures before he must come home again. Before any pictures are taken, the film and empty holders are placed into a special light-tight changing bag, which has light-tight cuffs sewn into it. You put your hands through the cuffs and then load the film into the holders. After the pictures have been taken, you use the changing bag to get the film out of the holders into either a light-tight box to be sent away for processing or a development tank.

ACCENTUATE THE NEGATIVE

The development process produces a negative image; the darker parts of the negative are made from tiny grains in the film which have been illuminated and then turned to silver. You make a print from a negative by projecting it onto photographic paper which, like film, turns darker when exposed to light. This reverses the light and dark of the negative, resulting in a positive image. If you don't want to do that, you can use a scanner to create an image file that can be processed by software to create the correct appearance.

HANDLE ANGLE PRINTING

You can see the camera handle on the left-hand side of the camera in **Figure 1**. It has a complex shape that made it very difficult for the author to print. If it was printed vertically, the handle came unstuck from the printer, causing the print to fail. If the handle was printed horizontally, the slot for the cable release, which runs the entire length of the handle, needed to be printed with internal support that was very hard to remove. In the end, the problem was solved by printing the handle at a 45-degree angle so that it had lots of contact with the print bed and needed no internal support. This was perhaps a bit wasteful with filament, but it did make for a very good-looking result. This is something that you might like to try if you have a tricky thing to print.

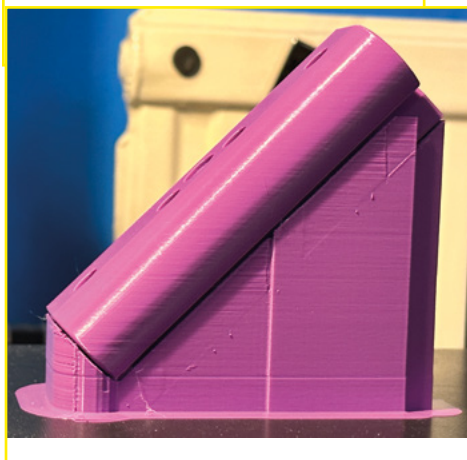
**“LOAD THE FILM INTO THE HOLDERS”****THE BIG PICTURE**

The camera takes pictures onto sheets of film that are 4×5 inches in size. These images contain lots of detail and, because

the lens is a long way away from the film, you can get beautiful out-of-focus effects. Lenses have a property called 'depth of field', which determines how much of an image is in focus. A lens with a large depth of field would take a sharp picture of both you and a tree in the distance behind you. A lens with a shallow depth of field will be able to take a sharp picture of either you or the tree, but not both. You might think that having more sharpness in a picture is a good thing, but you can get some very pleasing effects by blurring parts of an image. The picture of the duck → **Figure 3** looks better because the →

LARGE FORMAT CAMERA

**“OUR 3D-PRINTED
CAMERA...LETS PHYSICS
DO THE HARD WORK”**

trees and fence in the background are blurred. Smartphone cameras are very small and put their lenses very close to the image sensor. Because of the physics behind the way lenses work, this means a phone camera has a large depth of field. Phones use sophisticated software that can analyse an image, decide which bits are in the distance and blur them. The results can be impressive, but our 3D-printed camera just puts the lens a very long way from the film and lets physics do the hard work.

Figure 3 ↗
The lens was focused on the duck, which is very sharp. The trees in the background are blurred

DIGITAL VS ANALOGUE

A digital camera breaks a picture down into a grid of picture elements or pixels. Each pixel stores red, green, and blue intensity values representing the colour of that position in the image. An image is recorded by a grid of sensors producing light intensity values at each pixel. The value is the amount of red, green, or blue light falling at that pixel. These values are used to calculate a colour for each pixel. Analogue cameras use film coated with silver halide particles called 'grains', which are chemically changed when hit by light. Chemicals in the film developer convert the changed grains into opaque grains of metallic silver. Colour film uses three grain layers which are sensitive to different light wavelengths. During development, these are bound to dyes which react with the silver in the grains to produce the complementary colour for that primary. Red areas are green, green areas are red, and blue areas are orange.

You could say that film images are more 'real' because they have not been subjected to any digital process. A difficulty with digital cameras is that, because each pixel only measures one primary colour, the final of each pixel is calculated using the colour values of the pixels around it. This is why different digital cameras produce slightly different results; they each use different algorithms to combine the sensor values. An advantage of analogue photography is that the colour resolution is spread over the whole image. An advantage of digital photography is that there is no film to be bought and developed, and you can view the images as soon as you have taken them. Both have their place, and they are both great ways to take pictures.



CONTROLLING EXPOSURE

When you take a picture with your phone, the camera works out how much light the sensor needs to get a properly exposed image. When you take pictures with the printed camera, you need to set the shutter speed (how long the film is exposed to the light) and the aperture (the size of the hole the light comes through). The easiest way to do this is to use a light meter application on your phone. You set the speed of the film in the app (how sensitive the film is to light), point your phone at the scene, and then copy the reading values onto the camera.

If your shutter speed is less than a thirtieth of a second, you will need to put the camera onto something solid. Otherwise, camera shake will blur the image.

A camera can only capture a fraction of the range of light and dark areas in a scene; if you get your exposure wrong, you might find that the faces of your subjects are too dark or too light. You deal with this by measuring the light from the parts of the scene you care about. As you take more pictures, you can use this limited range to your advantage, making a subject stand out by blowing the background out to white or turning the background dark. Next, you will start using lights to control how the picture looks, and hey presto! – you are turning into a proper photographer.

PRINTING A CAMERA

The most expensive camera in the world is still just a box with a lens at one end and something light-sensitive (film or an electronic sensor) at the other. So, if you want to make your own camera, you only really need a light-tight box. However, it's not quite that simple. The

size of the box must exactly match the lens you are using. A lens has a particular 'flange focal distance' (FFD), which is the 'in focus' distance from that lens to the surface of the film. You need to make sure that the box you make is the right size for your lens. The website at hsmag.cc/WillTravel has a lookup table you can use to find the FFD for your lens. You can then select an appropriate design from the ones available.

The Will Travel body contains threaded holes you can use with 3/8" to 1/4" adaptors to allow you to put the camera on a tripod. There are three accessory shoes you can use for flash-guns, lights, or the viewfinder. There are also holes into which you can fit spirit levels. The handle can be used on either side of the camera body.

OCCASIONAL PHOTOGRAPHY

The 3D-printed camera brings a real sense of occasion to taking a picture. On a good day, the results will stand comparison with very expensive cameras. The lenses and shutters might be old, but the results they generate are very impressive and can be made into enormous images. Also, taking photographs 'the hard way' teaches you a huge amount about photography, and how to use the limitations of the medium to get the best results. If you are of a certain age, you might even find it fun to revisit the days of home development and seeing pictures appear before your eyes in the darkroom. The author has had a lot of fun with this and hopes you do too. □

FANCY FITTINGS

The lens mount is fitted onto the camera body using bolts that screw into brass fittings which are embedded in the camera body. The author had never used this technique before. It is a very quick and simple way of creating strong and reusable fittings.



To put the fittings into the camera body, you will need a special tip for your soldering iron. You can find one by searching your favourite e-commerce site for 'heat-set insert installation tip'. The brass fitting is heated up on the tip and then pushed into the hole in the camera body.

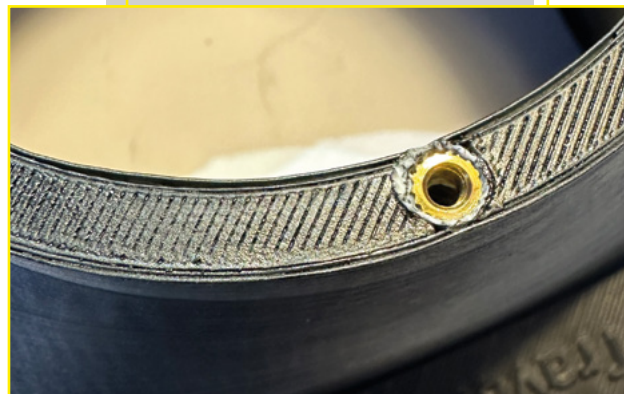

The author hasn't tested the fittings to destruction, but they seem to be a lot stronger.

HackSpace magazine meets...

Josef Průša

3D printers: they're quite a big deal

W

e've been having an awful lot of fun playing with/ thoroughly testing the latest offering from Prusa Printers,

the Mk 4. As part of that, we got the chance to pick the brains of Mr Průša himself, on the development process behind the XL and the new Mk 4, on 3D printing 3D printers, and why his suppliers hate their new X-ray machines. →





Above ▸
Josef Průša, at home among the printers, which are busy printing more printers

HackSpace Take us back to the beginning: how did Prusa Printers start?

Josef Průša I found out about 3D printing and I found out about the RepRap project, which was wonderful. But... I'm not going to say that I'm lazy, but I like to do things urgently. So when I saw the original Mendel model, and I tried to build it, it was just so, so complex. Sourcing the parts and putting it together took far too long.

At the same time, I started to think about how to do it a different way with the things that I had around. And that is how it originally got Prusa-fied – my Prusa Mendel Iteration 2.

But, from the very beginning, people kept calling it simply Prusa, because they didn't want to use the whole big name.

And that's how it all started. I was doing it as a hobby for three, four years. And then I knew at that time that the university where I was studying wasn't for me, I wasn't very happy with the university. So I ended my studies there officially and, on the same day, I started the company.

Sometimes when you start a company, you have to let everybody know what you're doing. But in my case, people had already started asking me to build printers for them long before I started doing so as a business. And they liked the design. So it was a little bit of a smoother start than usual.

In ten years, we grew it quite a lot: I now have over 800 employees. And we make as much as we can here in Prague. We just opened our in-house PCB assembly line, so we have absolute quality control on the PCB stage, which is crucial for the longevity and the reliability of the printer. We don't just outsource it somewhere else. Now, we manufacture in-house, so there can't be any way to hide failures on the PCBs.

HS And I saw that you've bought an X-ray machine. What's that for?

JP That is part of the PCB assembly line, to be able to check for the voiding. I can tell you a lot of suppliers hate the X-ray

machine. Because we don't use it just for the PCBs; we can check the quality of a lot of other parts without destroying them. Sometimes if you have to mill something down to check something, the suppliers will come back to you and say that whatever defect you've found was broken during the milling process.

This way they can't trick you. And this is the second time that X-ray technology has become unpopular with our suppliers, because we also use handheld XRF spectrometers – like an X-ray gun that you can put on metal or something; you press a button and it'll tell you the elemental parts of an alloy, for example.

Sometimes we get suppliers switching the alloy for something cheaper, which can also be tricky.

HS Do you still use 3D printers to print 3D printers in your factory?

JP Yes, we do. We have over 700 now; most of them are Mk 3s, but we will soon be switching the whole farm to Mk 4s to get more throughput.

But yes, we still do it every day. I think it should be required for 3D printing manufacturers to use their machines in production, because the 3D printing world would be a much better place now if everyone did.

We do some injection moulding, but those are the parts that we know aren't going to change, and it would be inefficient to make with 3D printing. But price-wise, it's not that big of a deal compared to injection moulding.

And the Automated Farm System is also getting quite complete; this will automate that process even further. We showed the concept machine at the Dubai Expo, representing the Czech Republic. It's basically an automated [print] farm: you have rows of printers and there's a picker which goes and takes the print plate out, puts the new one in, and everything is automated.

HS There's also something very nice about open-source machines being made by open-source machines. →

Above  The MK4 has been in development since Before the Pandemic (BP)

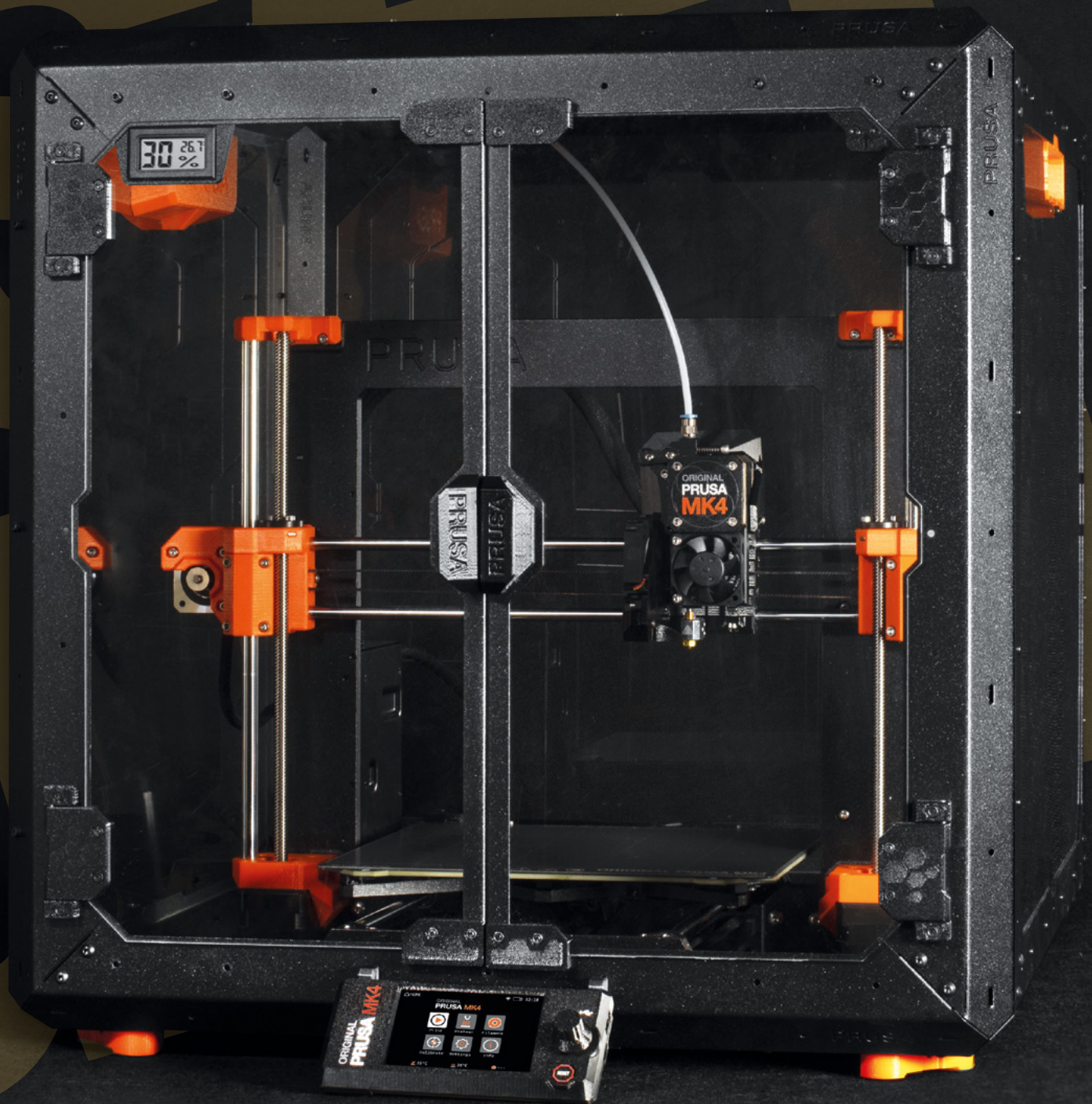



Above ▸
According to Josef, the current golden age of innovation in 3D printing is in danger if too many patents get in the way

JP It's self-replication at scale. I was never trying to push it beyond what is reasonable, and I think that's the key – to show our customers where it can be used. Because complexity in the 3D-printed parts doesn't cost us much, and the rest of the parts can be quite simple.

You can see this especially clearly on the previous Mendel model, the triangular shape where you can just use straight metal rods and all the complexity was held in the 3D-printed parts.

HS And you're making your own raw materials now, including tungsten filament.

JP Right! We were very pleasantly surprised because the first batch sold out quite quickly; we've since made a second batch, but evidently there is a big hunger for such materials.

And it is quite cool to read the tweets a couple of hours after I posted about its release. You see guys saying 'oh, I've been waiting for exactly this – I'm going to use it at work at the reactor shielding.' That's a lot of fun! And we want to do more of the high-end filaments and materials in the future. We have some cool things in the pipeline, but I cannot talk about these just yet.

Do you know what one of the biggest user bases for the tungsten filament is? People who like to go fishing. Apparently you can 3D-print part of the lure, to weigh it down. They didn't have filament for that before. So, on the one hand, you have reactors; and on the other hand, you have fishing. Even though I know the filament is expensive, you don't need to use all that much. So if fishing is someone's really big hobby, a roll of tungsten filament might be cheap compared with some of the higher-end products in that hobby.

HS Am I right in thinking that the initial demand for the tungsten filament came from a medical research centre in the Czech Republic?

JP The best way to come up with new products, the only way to come up with new products, is to try to solve somebody's needs. In this case, it was co-operation with a hospital. And we nailed that down. And on top of that, we are finding use cases for many, many, many other fields.

HS That brings us on to **Printables**, the site you launched a while back to host 3D models. How's that going so far?

JP So for me, I think our biggest competitor in this regard was a little bit left behind by its parent company.

I knew that we needed to do something; we already had **prusaprinters.com** as our domain name, for our own blog, so we used that.

I'm quite happy that we used the Prusa Printers name as a way to grow it.

"

We're not seeking any investments. Rather, we invest ourselves in local hardware startups

"

Because, at the moment when it was time to switch the name, we knew that it was a very good concept and we were not afraid to, you know, get such a wonderful domain as **printables.com**.

It was quite a hassle to acquire it, but I'm very, very happy about it. I think there's a chance that **printables.com** will be the largest [3D model hosting site] by traffic within the next year. I'm very, very happy about it.

HS That's not long at all.

JP Three years of hard work is actually a long time in the 3D printing space. Especially at the very beginning, it seemed like a very daunting task to

become the number one, but as we are growing and growing, I can see it happening quite soon.

It really is a service to the community for us. We still don't run ads – I'm very happy about this, that there can be some nice place on the internet that doesn't have hidden extra ways to squeeze money out of the user.

HS On a different note, I saw an update from the Elizabeth Holmes trial and it reminded me to offer you a belated congratulations on making it into the Forbes 30 Under 30 list.

JP Three years on from making that list and I still haven't been arrested!

What is more important to me than these awards is that my printers' users are happy with the machines, getting upgrades, upgrading them to the new models. That's what brings me joy. Not being on some list.

What good is being on a list? We're not seeking any investments. Rather, we invest ourselves in local hardware startups. There's not many people investing in hardware, especially if it's everyday working things. We backed an IoT bike lock and stuff like that, which is also important.

HS I guess that you're not working on a ChatGPT extension for PrusaSlicer then?

JP That will be interesting. What's going to happen in a year from now? If we make a prediction now of where AI will be in a year from now, we'll be laughing at ourselves in a year's time. We're obviously looking into using the new technologies in many places around the company. But I value security and safety and privacy quite a lot; I don't think many of the AI machine learning things which are now being hyped can be done quite safely or privately now. I think, in the rush to adopt this stuff, a lot of engineers at some companies are just pumping super-secret stuff into the GPT interface over the →

“

Basically, we just manufacture one big, solid part. There are no connection points; it is impossible for it to leak

”

internet. That is not what we would like to do. We would like to do all the machine learning on the premises.

Who owns the art created by AI?

Because it's just an amalgamation of all the data that was put in, it would be very difficult to prove a breach when anything with a non-commercial licence has been used.

What I tried myself is coding. Over the years, I got quite rusty in programming, I must admit, and I just wanted to test it out. So I did a little script to take data from one API and put it into another API. With me being rusty, it might have taken me three days. But with all the new AI stuff, it was done in an hour. I had to correct it a couple of times, but it was quite amazing.

If I may make one prediction, I think people will soon start to value face-to-face communication a lot more, because we'll get fed up of all the chatbots trying to pose as real humans.

HS You decided to add RGB LEDs to the Mk 4.

JP I mean, RGB LEDs are just fun. But, you know, sometimes when you have the printer at the other side of the room and you're printing at high speeds, you don't know, you don't hear if it's printing well or not. I wanted to have a quick way of glancing across the room and seeing what is happening with the printer, if everything is OK. The RGB LED is a good way to indicate that.

HS So, it's not because of the normal maker tendency to put flashy lights on everything?

JP No, no – I really try not to have parts on the machine which are just non-functional in 3D printing.

HS And the next-gen extruder – what was the breakthrough there?

JP The breakthrough was the combination of all of the parts in one. Basically, we just manufacture one big, solid part. There are no connection points; it is impossible for it to leak. People call it the blob of death, when they don't tighten the nozzle properly and the plastic gets heated and starts to leak, and you come to the printer and you just see the extruder covered in a huge blob of plastic. [That can't happen with our extruder.]

That is one of the things that we are very happy about. It is faster, it's more reliable, and more integrated. We wouldn't be able to do the load cell without it.

HS And are you planning to keep supporting the Mk 4 with upgrades, like you have done from the original Mk 1?

JP So, I would say with the Mk 3 we have a very good track record. We've been doing firmware updates and keeping everything top-notch for five years. And that is just the beginning.

We still support the Mk 2s and everything. So I would say we are ready to support the Mk 4 for quite a long time. That is what people love about us: the machine is not a paperweight after a year.

And I'm especially proud of the possibility to do the upgrades, because we have saved a lot of e-waste this way. People love it. And I love it too. □





Above  Lengthy software support means your Prusa won't turn into a paperweight overnight

IN THE WORKSHOP: Pomodoro timer

By Andrew Gregory

In which we try to do something simple and end up learning about I2C

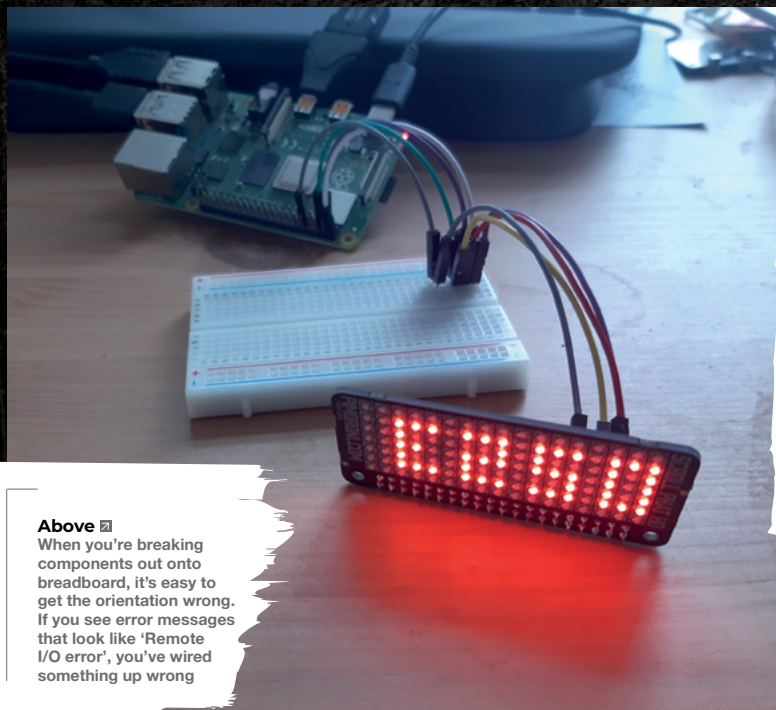

Above ■

When you're breaking components out onto breadboard, it's easy to get the orientation wrong. If you see error messages that look like 'Remote I/O error', you've wired something up wrong

T

his month, I set off with the intention of building a Pomodoro timer controlled by physical movements, rather than buttons or switches.

To capture the physical movements, I'd need an IMU, or Inertial Measurement Unit. Pimoroni sells one of these that uses the same motion sensor chip used in smartphones and watches to measure 3-axis acceleration, 3-axis gyroscopic motion, and 3-axis compass heading. I'd also need a screen (Pimoroni is selling off its lovely Scroll pHAT HD displays, featuring 17x7 LEDs, for £6.90 plus shipping), and a real-time clock module to keep the time. I also threw an atmospheric sensor into the basket, because why not?

For now, I'm sticking with Python, as not all the sensors support my first choice, MicroPython. The Scroll pHAT HD fits neatly on the GPIO pins, and with a quick download of Pimoroni's example code, it just works. Now to add the IMU sensor... and there aren't any pins left on the Raspberry Pi. This is impossible.

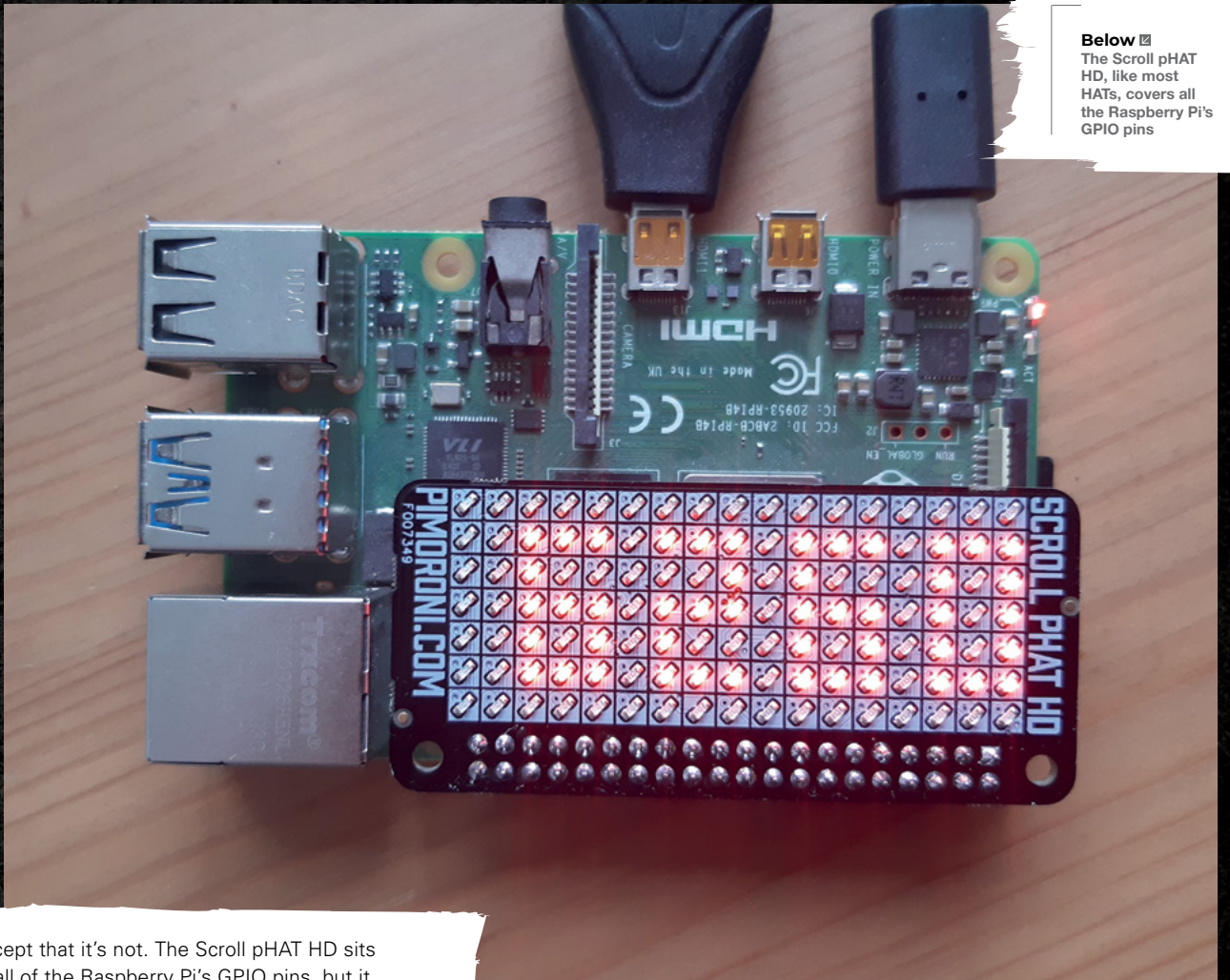

Below  The Scroll pHAT HD, like most HATs, covers all the Raspberry Pi's GPIO pins

Except that it's not. The Scroll pHAT HD sits over all of the Raspberry Pi's GPIO pins, but it can't use them all – surely no device needs three power supplies and eight ground pins, never mind all the rest of the GPIO pins? The answer was found at pinout.xyz, by Phil Howard. The device I'm using needs only four pins: 5V power, Ground, and GPIO 3 and 5. That's the good news. The bad news is that the IMU also needs to use those same four pins. It turns out that the atmospheric sensor and real-time clock also use those same four pins. Something is going on here, and that something is I2C.

I2C was invented in the 1980s, as a way for chips to talk to each other. Back then, they didn't →

The bad news is
that the IMU also
needs to use those
same four pins

FEATURE

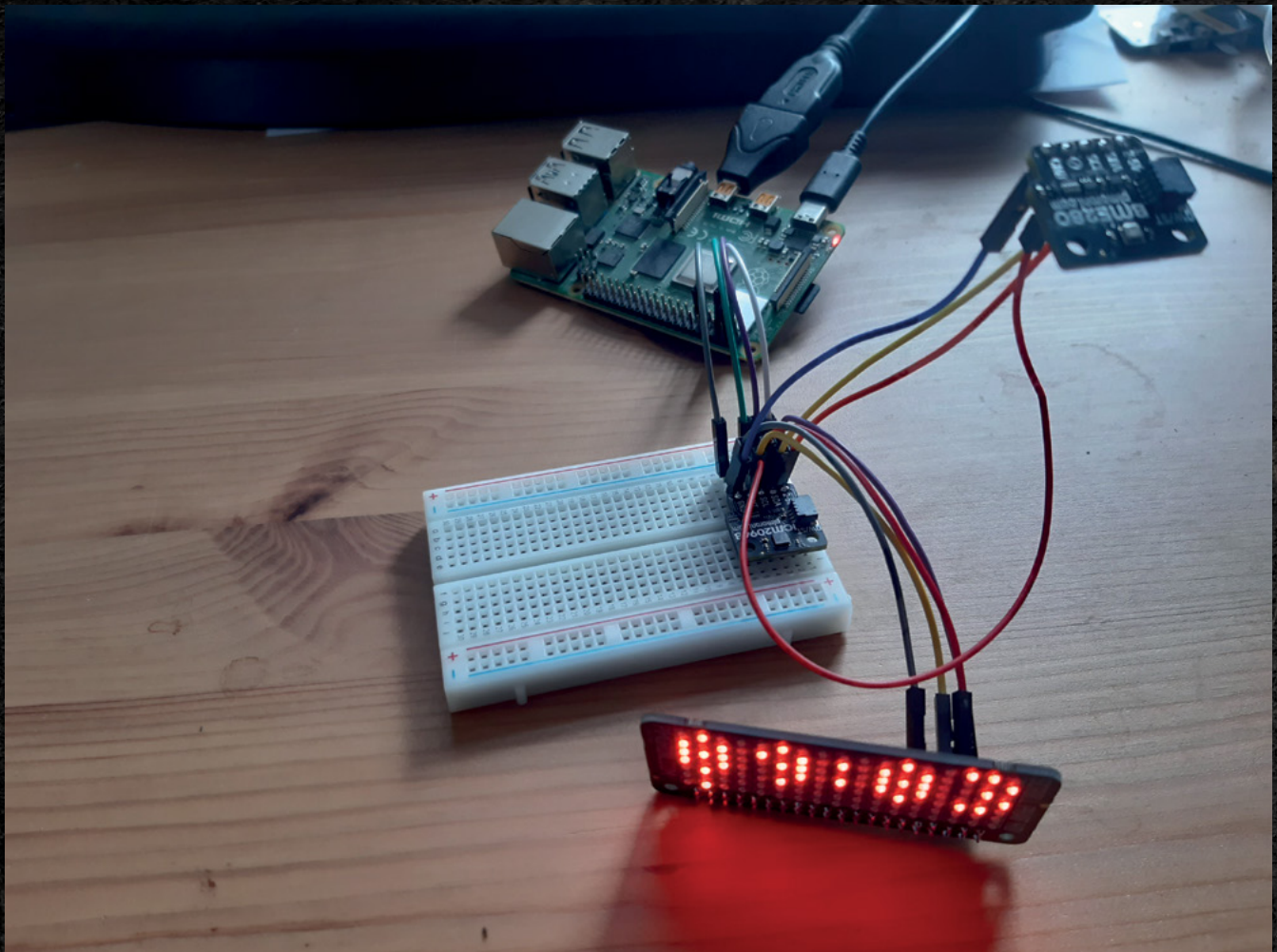

Above  With just three I2C devices connected, our breadboard is looking a little messy

Right  Some devices connect over I2C using the much smaller, neater JST connectors





have the chip shortage that we're mercifully coming out of right now. Rather, tech companies were starting to put chips in everything, as chips became radically smaller, cheaper, and an all-round better way of controlling devices than using discrete components. Chips are also known as integrated circuits, and it's from here that I2C gets its slightly clunky name: Inter-Integrated Circuit communication.

From this, we can infer correctly that every device that uses I2C has a chip on board. Each chip has a unique address, and I2C supports up to 1008 separate addresses – I'm going to need a bigger breadboard.

If you're using discrete components – say, an LED and a buzzer – you'd need to connect each one to a separate GPIO pin and switch each pin on or off to get current into the component. I2C is more

complicated than that. On a Raspberry Pi, the pins that send out data over I2C are pin 3 and pin 5; the I2C device will also need power (pin 1 or 2) and ground (Pin 9). Any I2C device can connect to these same four pins, provided it has a unique device address. The clock module I've been attempting to use has an address of 0x52; the environmental sensor uses 0x76 or 0x77.

To set up the I2C pins on a Raspberry Pi, go into the Rasi-Config tool by entering:

```
sudo raspi-config
```

Now, go to Interface Options, then to I2C. Enable I2C by selecting Yes, and choose to enable I2C every time the Raspberry Pi boots.

Failure is the first step in learning; this has been a frustrating learning curve, but now I know what's possible, we can get cracking. ▣

Above ▣
The gear we've chosen for this build all uses the same small set of GPIO pins. This is a problem...

THE *Official*

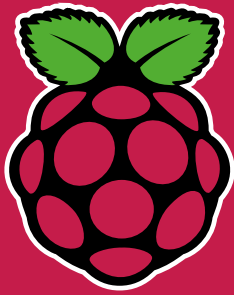

RASPBERRY PI HANDBOOK 2023

200 PAGES OF RASPBERRY PI

- QuickStart guide to setting up your Raspberry Pi computer
- Updated with Raspberry Pi Pico and all the latest kit
- The very best projects built by your Raspberry Pi community
- Discover incredible kit and tutorials for your projects

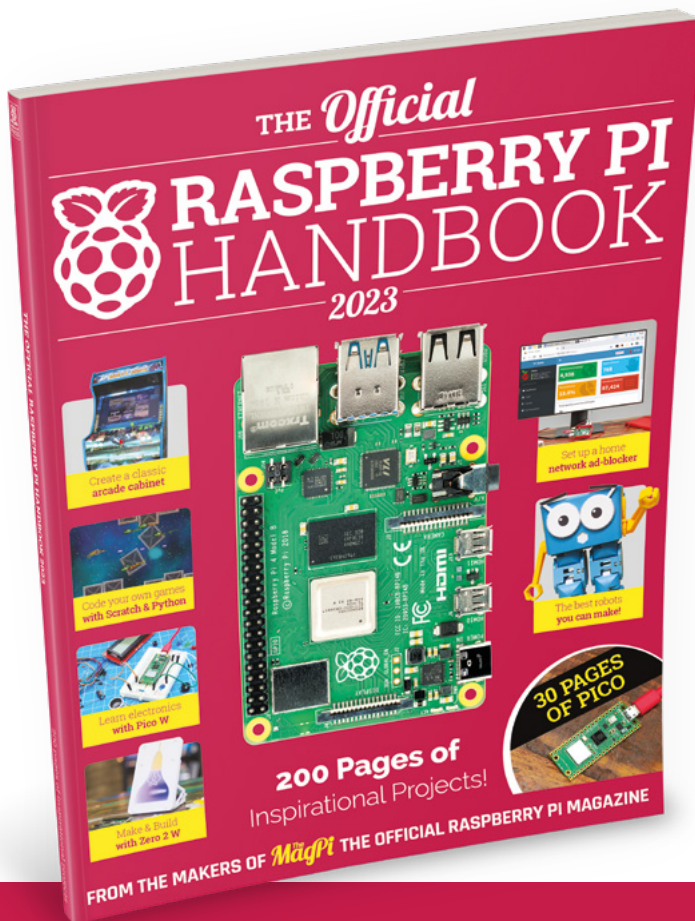

Buy online: magpi.cc/store

FORGE

HACK | MAKE | BUILD | CREATE

Improve your skills, learn something new, or just have fun tinkering – we hope you enjoy these hand-picked projects

PG
60

PERSONALISED CARDS

Use NFC to bling up your greetings cards

PG
66

LET THERE BE LEDS

Get started with this basic component

PG
70

PRINT IN PLACE

Working mechanisms straight off the print bed

PG
72

AUTOMATIC LIGHTS

Remove your light switch and save seconds every day!

PG
54

SCHOOL OF MAKING

Start your journey to craftsmanship with these essential skills

54 KiCad



PG
78

E-SCOOTER

Build your own personal transporter

PG
82

AI DESIGN

Can ChatGPT write OpenSCAD code?



Getting started with KiCad, PCB layout

In this second part of the series looking at PCB creation with KiCad, we lay out our PCB ready for fabrication



Jo Hinchliffe

@concreted0g

Jo Hinchliffe is a constant tinkerer and is passionate about all things DIY space. He loves designing and scratch-building both model and high-power rockets, and releases the designs and components as open-source. He also has a shed full of lathes and milling machines and CNC kit!

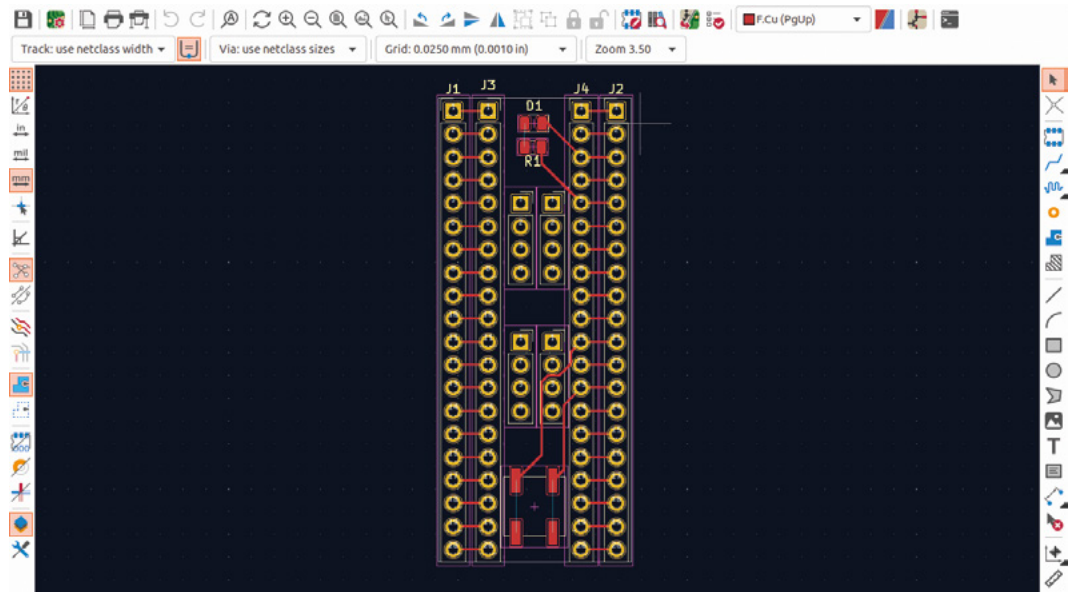

In the last issue, we got our schematic for our Pico add-on board created, and we assigned each schematic symbol a footprint which represents the individual component we are adding for each part of the design.

In this issue, we will finish this starter project by laying out the PCB design ready for manufacture. If you haven't opened KiCad, do so now. Open the previous project and select the PCB Editor icon from the available applications (Figure 1). If you have opened the project and the Schematic Editor, you can jump to the PCB Editor by clicking its icon in the Schematic Editor toolbar.

Having opened the PCB Editor, you should see a similar page to the Schematic Editor, but in black (Figure 2). You'll notice it is blank, so the first action is to pull in our footprints. To do this, we can click

the 'Update PCB from Schematic' icon. This opens a window, and we can simply click the Update PCB button and then click the Close button (Figure 3). Once back in the PCB Editor, we now should have our design as a collection of footprints attached to our pointer. Left-click to place the component bundle somewhere in the middle of the page (Figure 4).

The PCB editor has a grid feature which snaps footprints at useful points. In our current case, the pin socket footprints will snap with the centres of the pad holes on the grid. As the Pico conforms to 2.54 mm pin spacings, it's useful at this point to set the board editor grid to '2.54 mm (0.1000 in)'. You can select this from the centre drop-down menu on the upper toolbar. We can now align our two pairs of pin socket footprints so that they are in line with each other horizontally.

Figure 1 Our completed routed PCB design

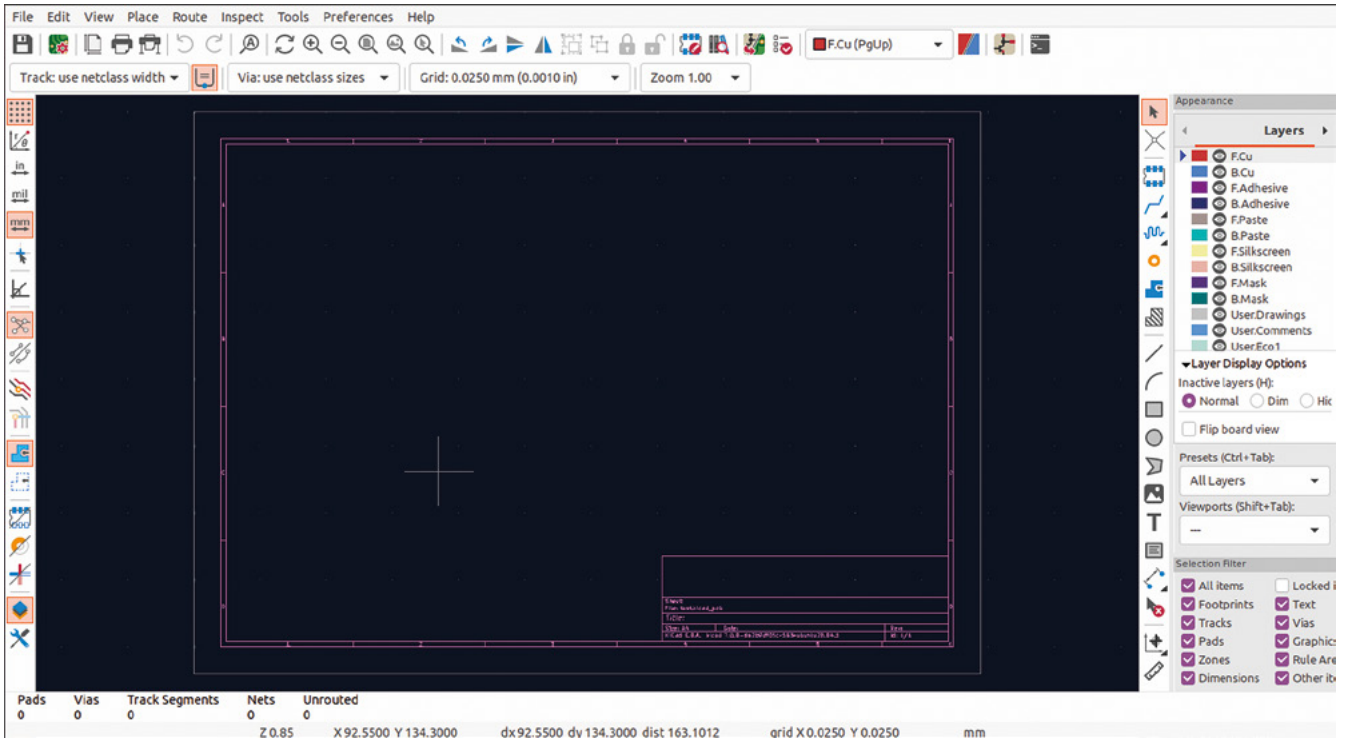

Figure 2 The blank PCB Editor ready to import our footprints

Next, move one element of one pair so that it lies two grid dots away from its connected pair. You do this by clicking on the centre of a pad on the footprint and then pressing **M**, similar to in the Schematic Editor. If you only move it across one grid dot, they will overlap. You should see a collection of small white lines connecting the pads between the two connected footprints – this is called the ‘rat’s nest’. We will remove these white lines when we lay the trace connections. It’s important that our board matches up to a Pico, so we used the dimensional diagram (**Figure 5**, overleaf) taken from the Pico data sheet documentation, available here: hsmag.cc/PicoDatasheet. You’ll notice that the distance between the vertical rows of pins is 17.78mm – this equates to 7×2.54 mm. This is why your Pico fits perfectly into a prototyping breadboard. Move the remaining outer pin socket footprints so that it is on top of one of the pairs you have placed correctly, and then move it seven grid spots to the right. You can now arrange the last footprint to be two grid spots inside. The outside pair of footprints should now match a Pico’s pin →



The PCB editor has a grid feature which snaps footprints at useful points



Figure 3 The Update PCB from Schematic window primarily brings in the component footprints and connectivity, or can be used to apply later changes to a schematic design

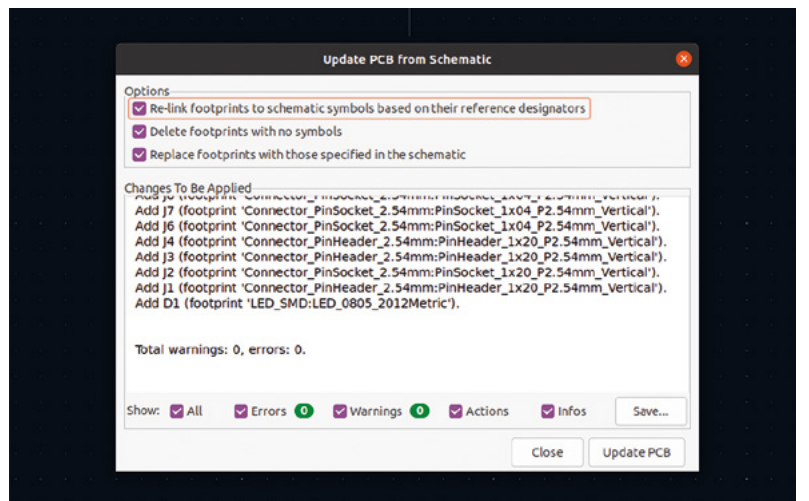

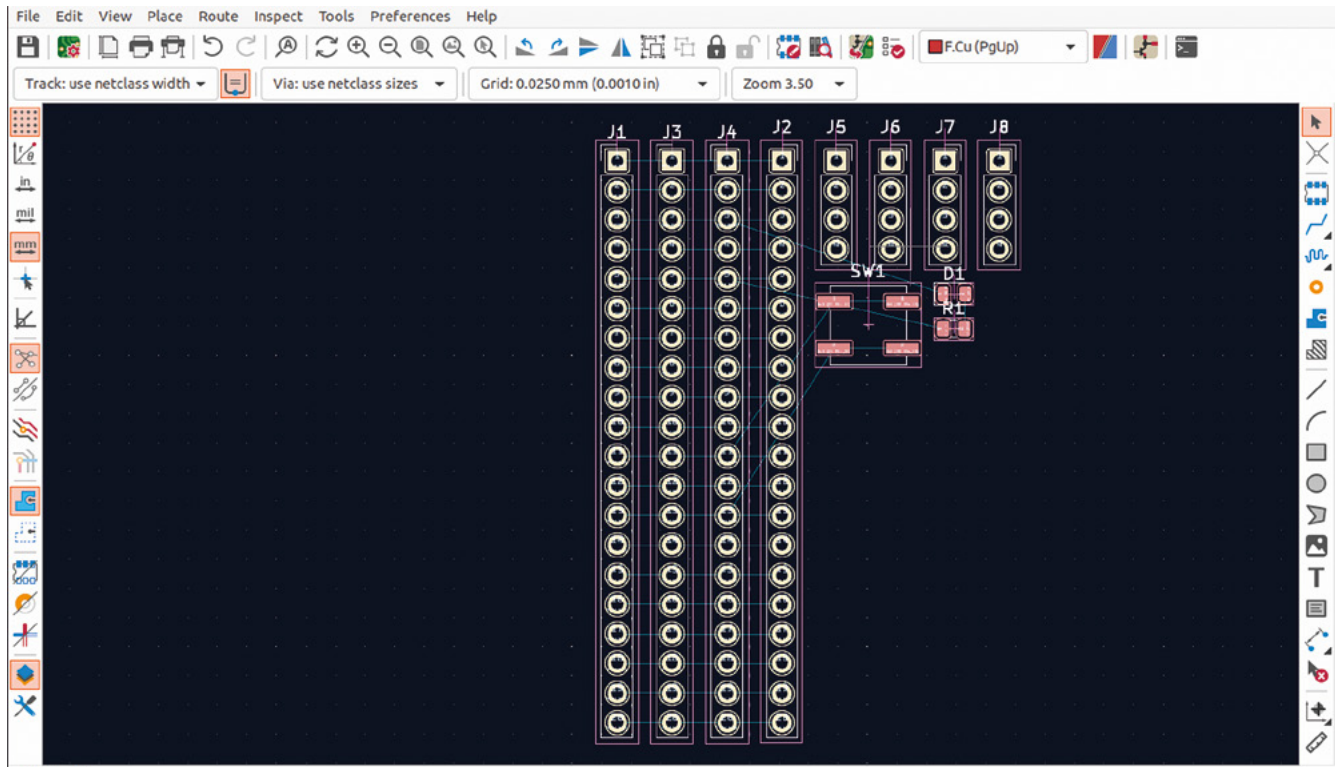
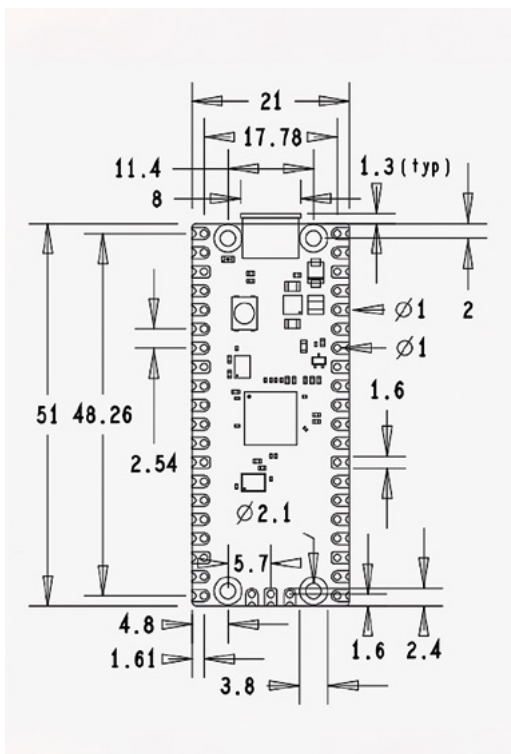

Figure 4

Our component footprints imported, with the rat's nest a representation of the connections between components and pads made of small lines

Figure 5

A technical drawing of the Pico taken from the data sheet gives us the dimensional information we need



positions, and the inner footprints should be close to them, and parallel. So far, we should have only been working on the F.Cu (PgUp) layer, which is the top copper layer on our PCB board. Before we route the tracks between our footprints, double-check that you are on this layer by checking the drop-down menu on the top toolbar.

LEAVE ONLY FOOTPRINTS

Next, we can wire the pads on the opposite footprints together. To do this, select the Route Tracks (X) icon, then click the centre of a pad and drag the track over to the centre of the opposite pad. The track should be red, indicating that it's on the top copper layer. If we, for example, were to move to the B.Cu (PgDn) layer, the default colour for tracks on the lower copper layer is blue. Continue and connect all pads together, noticing that the rat's nest lines disappear as you do so.

Referring to our Pico technical drawing, it's a good time to define the shape and edges of the board. To do this, we can use the uppermost drop-down menu to move from the F.Cu (PgUp) layer to the Edge.Cuts layer. On this layer, we can use the Draw a Rectangle tool to create a cutout shape for our board. Before we select this tool, let's switch

QUICK TIP

Remember, a lot of your keyboard shortcuts are universal. For example, **F1** and **F2** zooming works in both the Schematic Editor and the PCB Editor.

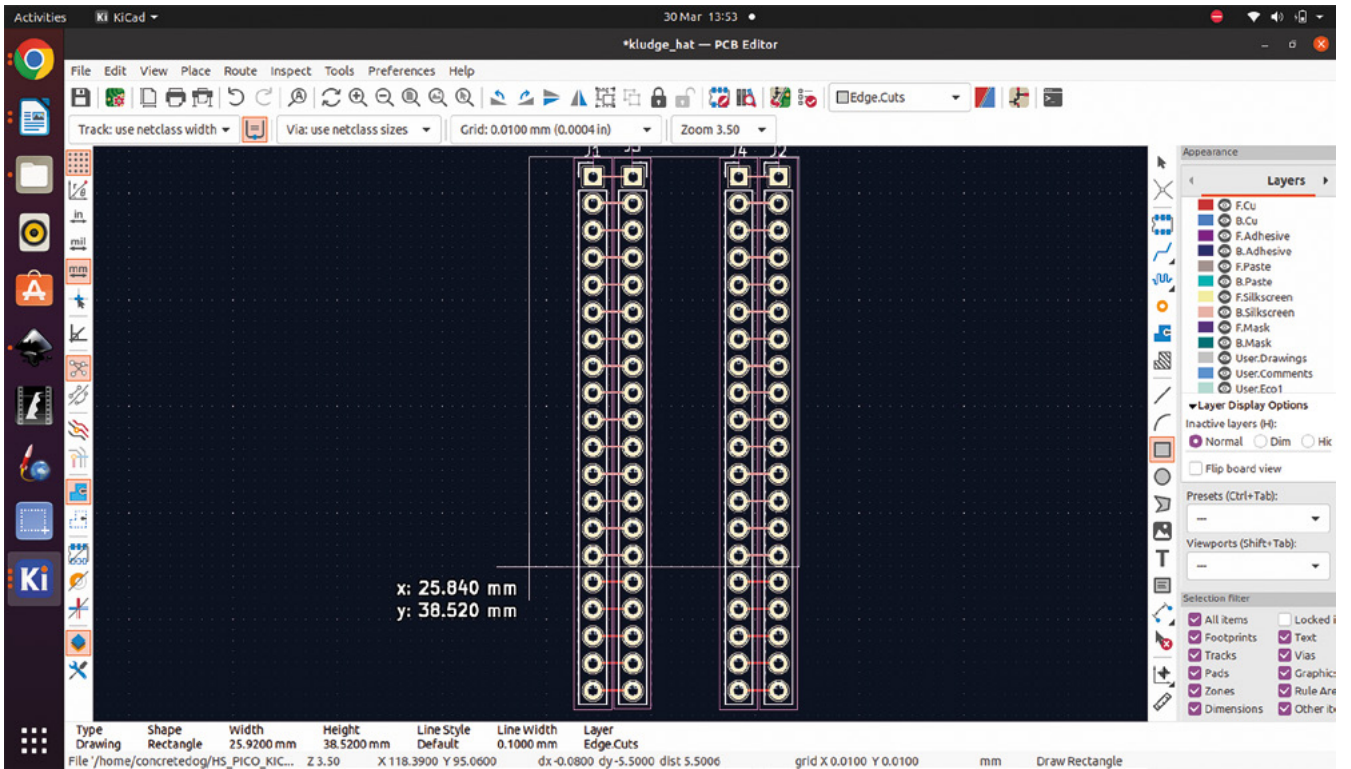

the grid to a more useful spacing. Select the 1 mm grid spacing, then left-click the rectangle tool. Left-click anywhere in the PCB Editor page and drag a rectangle (Figure 6). The rectangle should be snapping to the grid – we can drag it out until the labels tell us we are drawing a 21 mm width by 51 mm height rectangle. Left-click one more time to create the rectangle. Moving back to the Select Items (S) tool, we can now select the rectangle and press the **M** key to move it into position. Notice

“ Connect all pads together, noticing that the rat's nest lines disappear as you do so **”**

from the Pico technical drawing that the outside edge of the Pico sits 1.61 mm from the centre of the pin pad position. To position this accurately, we reduced the grid spacing to the smallest listed and used a technique to measure distances on the page. If you press the **SPACE** bar at any time when in the PCB Editor, you might notice that values labelled 'dx', 'dy', and 'dist' are set to zero. This is very useful as you can place your pointer at a point, say the centre of the top rightmost pad, press →

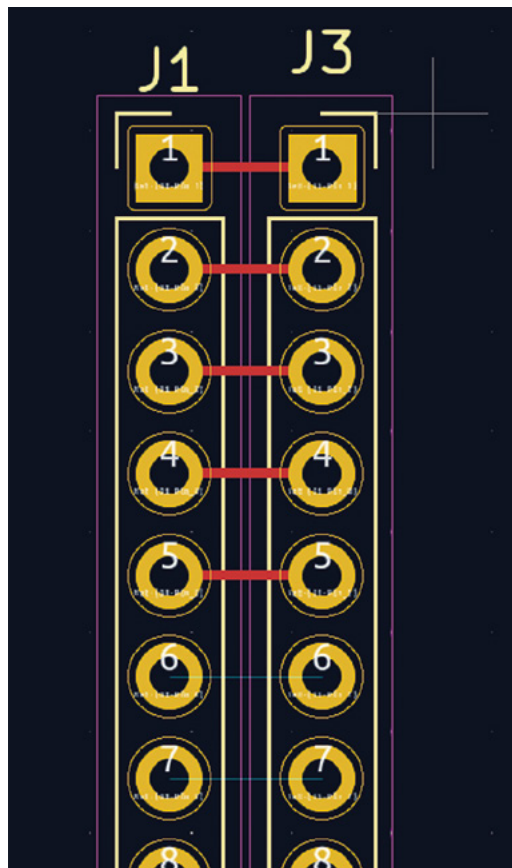

Figure 6 Drawing a rectangle that defines the cut edge of the PCB board

Left Routing tracks to connect the pads together

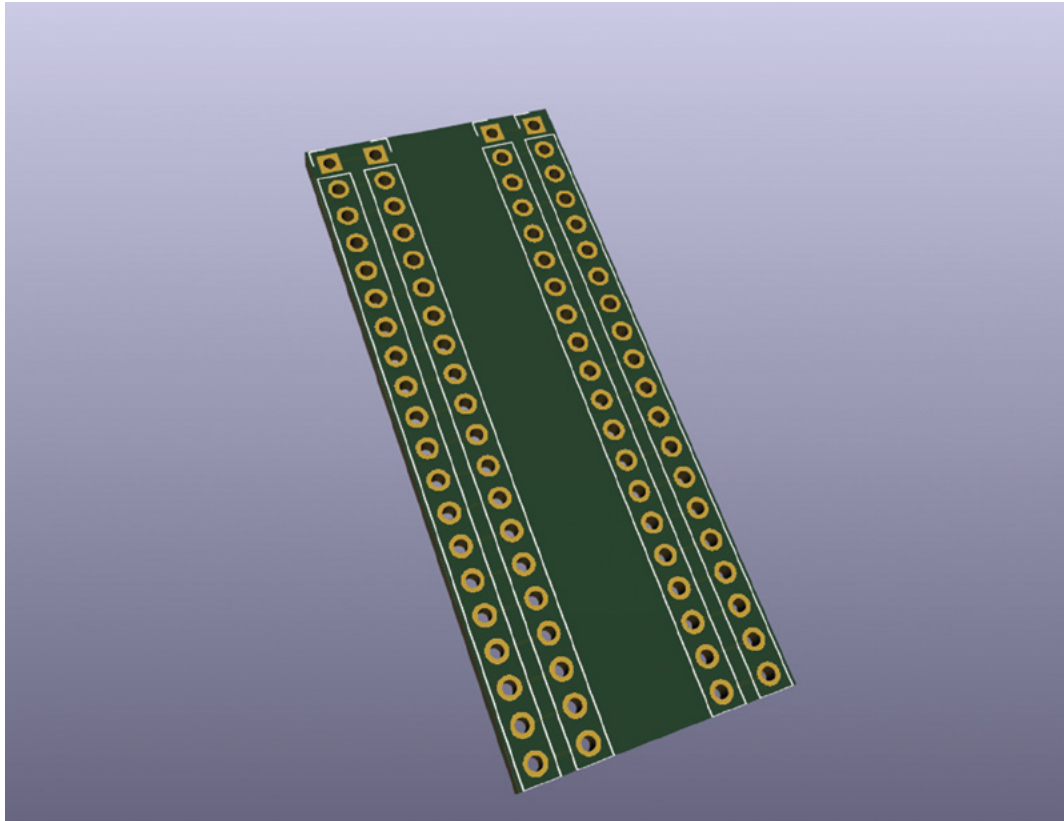

Figure 7  A first glimpse of our rendered PCB board

QUICK TIP

There are lots of drawing tools to create more complex edge cuts in KiCad. Also, in future articles, we'll look at importing graphical elements from other drawing software, such as Inkscape.

ASSIGNED AND SEALED

One point we mentioned earlier in this project is the idea that KiCad schematic symbols are generic – we assign the hardware footprint to them using the Assign Footprint tools. As an experiment, we could now show the advantage of this. Say we have our PCB layout completed and ready for manufacture, but after checking, we realise that our B3SL-1002P button package is not available or in stock anywhere. We can simply go back to the Schematic Editor and click the Assign Footprint tool icon. We can then edit the SW_SPST symbol to have a different, and hopefully, in stock, component. For example, we selected the B3SL-1022P footprint package, double-clicking it to ensure it is added to the centre console list. You can then click Apply > Save Schematic > Continue, and then click OK to close the dialog. Moving back to the PCB Editor, you can then once again click the Update PCB with changes made to the schematic (F8) icon, or press **F8** on the keyboard and the board will update with the replacement footprint added. If, as in this example, you replace the part with another part that is virtually the same footprint, you might not need to rewire the traces, but, of course, you should check and adjust connections and positioning as required.

the **SPACE** bar to create a zero or datum point, and then move the pointer to, in this case, the edge cut rectangle. We can then use the dx and dy values to help us position this, or anything we need to, accurately.

Once we have positioned the board edge rectangle correctly, we can get a first glimpse of our board in the 3D Viewer. You can actually look at the board in the 3D Viewer before adding an edge cut, and it will render to a rectangle size that is the smallest that can accommodate all the footprints currently in the PCB. To view the PCB, click View > 3D Viewer. You'll see the board, but you'll notice that all the 3D models of the header sockets are all placed into the rows of holes. In reality, we would only want headers on the outer rows installed on the back of the board, with the inner rows left unpopulated, or possibly populated with header pins. We could edit the board and the component footprints to reflect this, but for this 'getting started' example, we can click the Toggle 3D Models for Through Hole type Components (T) icon to turn off the models (**Figure 7**). In future articles, we'll explore not only using correct 3D models but we'll

look at how we can add custom 3D models to our libraries.

FLOOD ZONE

We can now continue to arrange and wire our remaining components. For the LED and the switch/button, we are wiring traces directly to the pin connections to the Pico – this is perfectly OK, but in future parts of the series, we will look at using copper flood zones. A copper flood zone is where an area on a layer of a PCB is flooded with copper that is connected to a certain ‘net’, with the net value being chosen by the user. This means, for example, that we could make a PCB where everything on the back layer is a GND-connected copper flood, then any pads that connect to ground simply join the

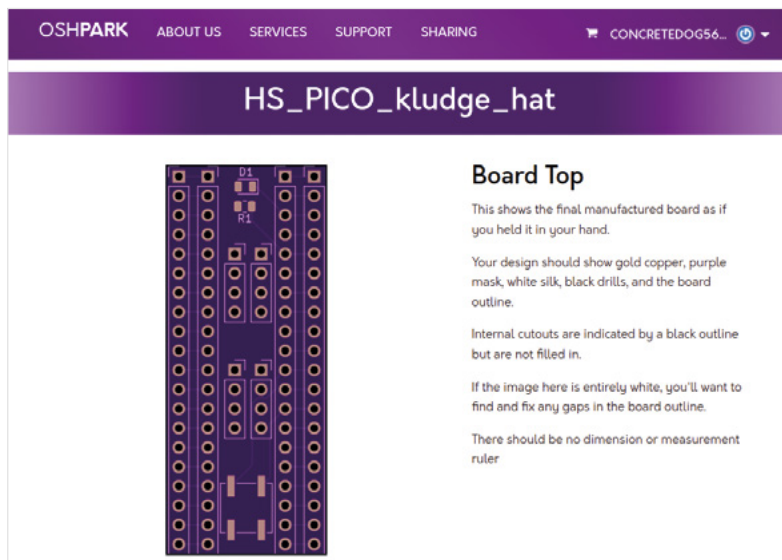
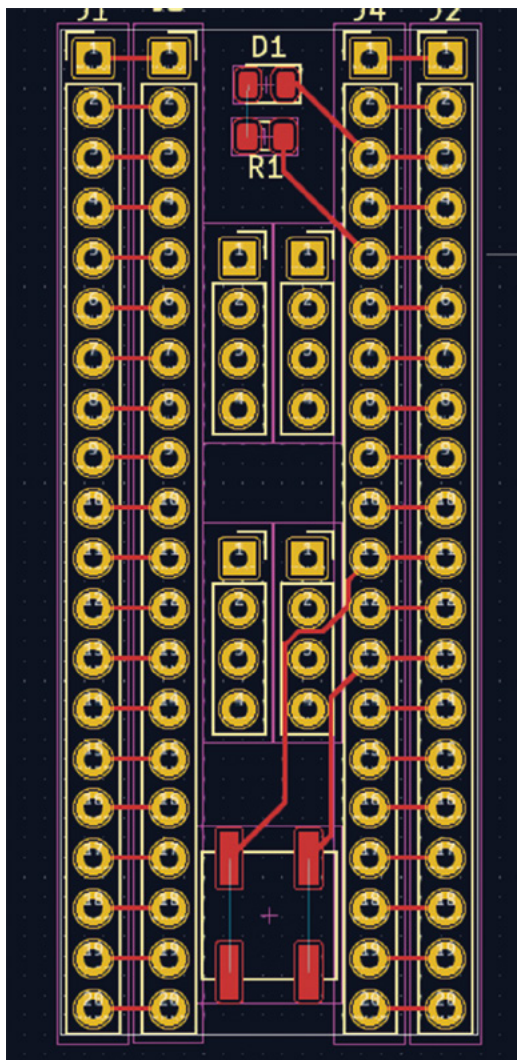

flood with small traces. This can dramatically reduce the amount of traces in more complex designs, making them easier to route.

Finally, how do we get this board made? Well, there are lots of options – we will look at many of them throughout these articles. Globally, there are lots of services available from companies to manufacture and even assemble your boards. These services may need different approaches in terms of what information and files you need to upload to get the job done. Often we need to export Gerber files for each layer of the PCB, and also drill files which show the position and size

Above

We'll use numerous PCB fabricators in this series, but a great place to start, where you can directly upload KiCad PCB files, is OSHPark

Below

Our complete PCB with all components placed and routed

//

In a few weeks – often less – you'll have 'Perfect Purple PCBs' through your door!

//

of holes. Some companies might have limitations on what size holes they can produce and what tolerance they can produce the board too. We'll explore this in future articles, but the simplest way, if you wanted to get this board fabricated to an excellent standard, is you can upload the file that ends '.kicad_pcb' to the OSHPark website (oshpark.com). The website and service are brilliant. In-browser, it creates numerous renders of your board, which you can then inspect and check to see if they are correct before adding the PCB to your cart to be manufactured. In a few weeks – often less – you'll have 'Perfect Purple PCBs' through your door! □

Make interactive greetings cards with NFC tags

Pep up that boring greetings card with a fun NFC tag. **Nicola King** explores the possibilities



Nicola King

@holtonhandmade

Nicola King is a freelance writer and sub-editor. She vows to spend less time searching for makery paraphernalia, and more time creating useful items from her (substantial) stash.



Above A selection of different NFC tags – when choosing which tag to use for a specific project, you'll need to consider memory requirements, read/write cycles, where it will be positioned, whether it needs to be waterproof, how it will be attached, and so on

YOU'LL NEED

- ◆ A ready-made greetings card, or card-making supplies
- ◆ An NFC tag, e.g. hsmag.cc/TimeskeyNFC
- ◆ An NFC-enabled smartphone
- ◆ An NFC app downloaded to your phone (such as NFC Tools)
- ◆ A pen

There are lots of fun ways of using near-field communication (NFC) in our day-to-day lives. In this tutorial, we will be taking a humble greetings card and hiding an NFC tag inside it in order to gift an unconventional digital surprise. The best part is that you need very little in terms of 'equipment' to get going, it takes next to no time to set up, and you really don't need to be a tech whizz either, so let's jump right in.

STEP 1 ASSEMBLE YOUR SUPPLIES

Let's firstly gather together what we need for this project. In the interests of speed, we've used a ready-

made greetings card for this endeavour but, if you have the time, you could really push the boat out and make your own card for that extra handmade touch, whether that's using a digital cutting machine such as a Cricut which can cut out your chosen design, or just purchasing some blank cardstock and card-topping ephemera from a craft store for you to piece together in an artful manner – the choice really is yours.

Next, let's talk about NFC tags, and the many different options available. These unpowered tags come in various shapes and sizes, but are generally on the small side, fitting in the palm of your hand, and they are usually super-cheap to buy. We picked up a handy selection pack from Amazon which

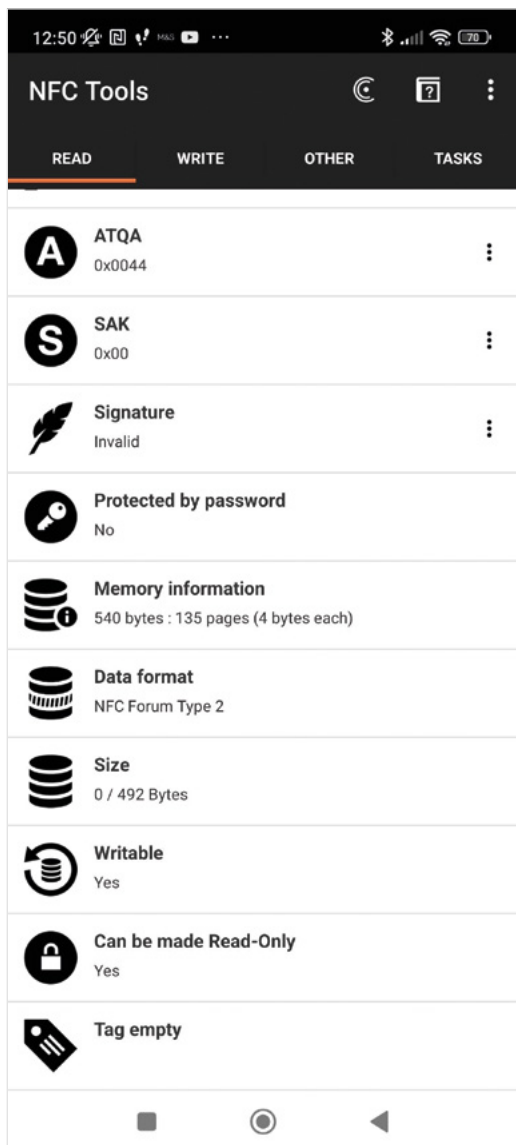

contained some black and clear-coloured coin-shaped sticker tags around 2.5cm in diameter, some similar coin-shaped NFC cards, some mini NFC cards, some credit card-sized transparent NFC cards, and five cool-looking epoxy NFC keychains. In all, the £15 pack contained 30 pieces, which offers a lot of flexibility for different NFC-related projects. Given that we are working with a greetings card, we chose a thin, light sticker tag for this venture as it will fit very neatly inside the card. The beauty of the sticker NFC tags is their simplicity and the fact that you can stick them virtually anywhere, so they can be used in places that other technologies can't.

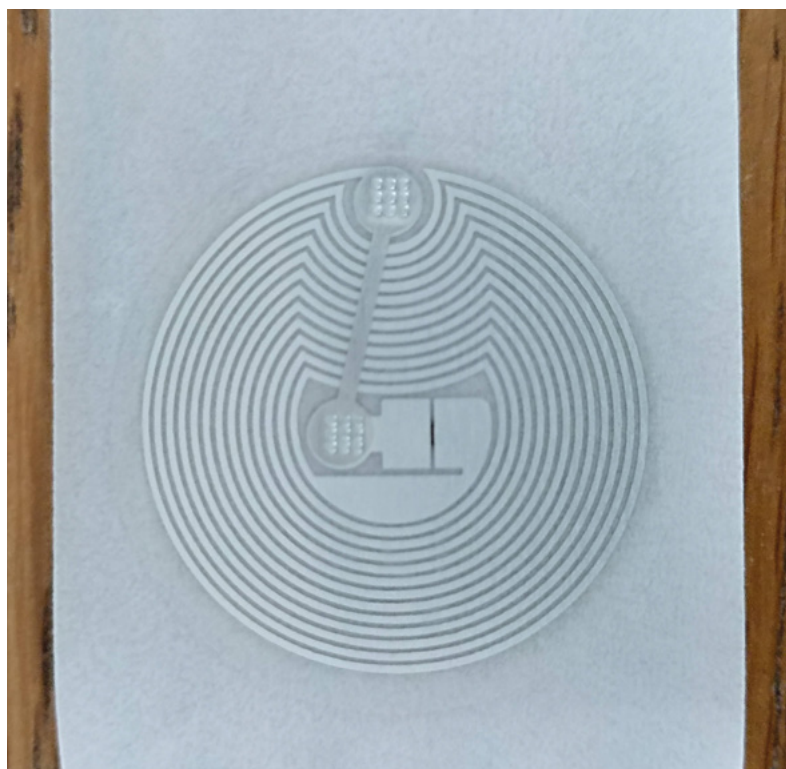

Above A close-up of a sticker tag, showing the coiled circuit which will take its power from the nearby smartphone or other device

NFC tags vary in terms of their memory capacity and read speeds. The tags that we bought were all described as NTAG215, which means they have a medium-sized memory capacity (504 bytes). You can purchase tags with a bigger memory, such as those labelled NTAG216, which hold 888 bytes – it really depends on your specific needs. It's worth bearing in mind that tags with less memory will generally be

“ You could really push the boat out and make your own card for that extra handmade touch ”

slightly less expensive. It's also worth pointing out that you can rewrite many NFC tags, which is clearly a carbon footprint-reducing route to take. So, check this out before you purchase.

Now, let's turn to our smartphone. The first thing we need to do is ensure that it is NFC-enabled. On our Android phone, we went into Settings, then into a sub-section called 'Connection and sharing', under which we found 'NFC (allow data exchange when this device touches another one)' switched on. Every phone is different of course, but this setting should be easy to find – on iPhone, it should be in the Control Centre.

Next, we need to download an appropriate NFC tag writer app that will enable us to program our →

Left The Read tab of the NFC Tools app gives you the details of the scanned tag. As you can see, this one is empty of data

Make interactive greetings cards with NFC tags

TUTORIAL



Right

After selecting the Write option, hold the phone near to the NFC tag to write the selected records to it

Below

We stuck an NFC tag to our greetings card with a helpful message for the recipient

tag. There are a number of suitable apps available, including NFC Tools, NFC Tag Reader, NFC TagWriter, and others. We chose to download NFC Tools, a popular and easy-to-use app which allows you to read, write, and program tasks on NFC tags and other compatible chips.

QUICK TIP

Try not to bend NFC tags too much, especially the very thin ones – if the antenna breaks, the information stored on it is unlikely to be recoverable.

STEP 2 PROGRAMMING YOUR TAG

Once you have the app installed and launched, go to the 'Read' tab. Put your tag on the table and hold your phone over it. All of the technical data regarding the tag should appear on your phone and, as ours is a new, blank tag, it is empty of data as we've obviously not programmed anything yet.

We are sending a birthday card and, to our tag, we want to add a link to a music video (Kool and the Gang singing *Celebration*) from YouTube to wish the recipient a happy birthday. You could, alternatively, send them a link to a digital voucher, if you are feeling generous. The choice is yours, but the point is that we are going to add a URL to the tag in this next step. Go to the 'Write' tab and select 'Add a record', and then select 'URL – Add a URL record'. Click in the URL box, and paste in the link. Press OK. Then select 'Write/XX bytes' (the XX relates to the number of bytes and will vary). The app will then invite you to approach your NFC tag with your phone to write that URL to the tag. We found that we had to put the top of our phone very close to the tag, but it worked and we received a 'Write Complete' message. Click on OK, and you have successfully written a URL to the tag. If you want to test it, just hold your phone close to the tag and the page should open.

WHAT IS NEAR-FIELD COMMUNICATION?

NFC is a technology that has gained momentum in recent years, and is a set of communication protocols that enables wireless communication (sharing data, media, and more) between two electronic devices that are in close proximity to each other. Its history is rooted in radio frequency identification technology (RFID), and NFC is really an evolution from RFID tech, with both NFC and RFID having distinct use cases. NFC technology is used in things like credit cards, ID cards, transport passes, car keys, access badges, hotel access keys... to name but a few.

NFC tags are passive devices with no power of their own, and consist of a thin copper coil (antenna) and a microchip, which is used to store very small amounts of data, such as a URL or a password, for example. These tags operate at 13.56MHz. The coil allows the tag to wirelessly receive power from the NFC reader (in this case, a smartphone) through electromagnetic induction. NFC tags are activated directly by the magnetic field of the NFC sensor of the smartphone/other device that reads them. So, when the smartphone comes close to the tag, the tag is instantly energised and transmits the stored data in its microchip to the smartphone.

Officially, the two electronic devices that are communicating with each other should be about 1.5 inches (3.8 cm) apart, but they can be up to 4 inches (10 cm) from each other in practice. In our simple tutorial, we have paired an NFC-enabled smartphone with an NFC sticker (a very popular and practical form of NFC tag) which gets its power from the phone.

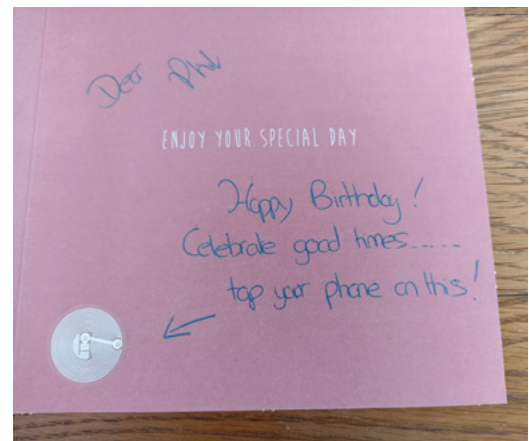

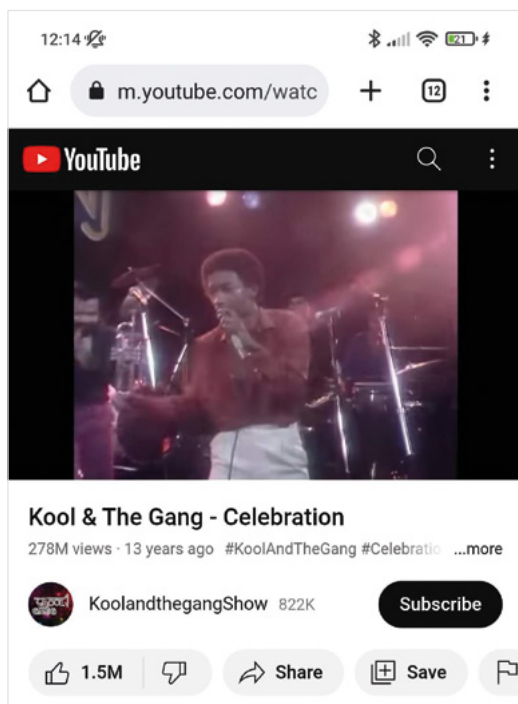

STEP 3 TAP TO FINISH

As already mentioned, we used a sticker NFC tag, peeled it off its backing and placed it inside the card, with a note asking the recipient to point their phone at it. Note that when the recipient taps their phone on the tag, the link should open, but they may be first asked which browser they want to use if no default browser is already set on their phone. It's also worth noting that you can add multiple records to a tag, so we also added a text message.

There are many other options too – for example, you could add details of your Wi-Fi router to a tag, so that any visitors to your home/office can just tap it to gain access. You can add a link to videos, social networks, phone numbers. Have some fun playing with NFC tags – for example, we wanted to know the best route to a local garden centre. Selecting 'Add a record' in the Write tab of NFC Tools, we chose 'Open a destination address'. Next, we input the name of the garden centre, selected 'Write/XX bytes', wrote it to the tag as before and, when we read the tag, were

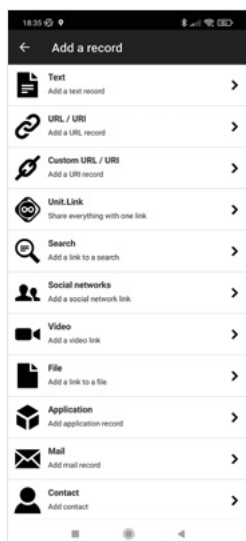

“ Have some fun playing with NFC tags – we wanted to know the best route to a local garden centre ”

presented with the best route in Google Maps. You can also set passwords for the tag, lock it, erase data, and so on.

Additional options are available in the Tasks tab when you download the NFC Tasks companion app and grant it permissions. These include the ability to alter your own phone's controls, e.g. muting the volume, as well as setting timers and alarms.

It's even possible to use NFC tags to turn on lights, unlock doors, and perform other actions in your smart home setup. There are various ways of setting this up, such as using iPhone Shortcuts or sending custom URLs to an app like Home Assistant to trigger an automation.

So, what are you waiting for? Get yourself some NFC tags, download an NFC app to your smartphone, and see where it takes you. □

Left ♦ The NFC tag in our birthday card links to a YouTube video of Kool and the Gang singing *Celebration*

Below ▣ Some of the many record options available in the NFC Tools app

OTHER IDEAS FOR HOW TO USE NFC TAGS

We can literally only skim the surface with regards to what you can use NFC tags for. The possibilities are numerous, and we'd recommend you read around the subject a little to get some inspiration, but here are a few of our favourite suggestions:

- Make your own virtual business card – cardstock business cards are so old hat! Just program your contact information, social media details, website etc. onto your tag and away you go. The credit-card-sized NFC tags would be perfect for this. This handy explanatory video is well worth a watch: hsmag.cc/NFCBusinessCard.
- If you want smart home automation and some handy life hacks, NFC tags are just the ticket. You can use them to help with tasks around your home such as turning lights on and off, setting a kitchen timer, setting an alarm etc. You could even automate your grocery list – stick a tag to the side of the bread bin, for example, and scan it when you are out of bread so that 'bread' gets added to your shopping list. Take these ideas and just run with them! Try this instructional link out for more information: hsmag.cc/NFCSmartHome.
- Send secret messages – children might like this one. Just program your tag with your message and hide it for someone to find. Amusing more than practical...
- Lessen the chance of lost PE kits – if you have offspring who are prone to losing their PE kit (voice of experience speaking here!), then why not program their name, the name of the house they are in at school, and any other pertinent details into a waterproof and durable key fob NFC tag and attach it to the PE kit? Unlike a Bluetooth tag, it lacks the range to help you find it yourself, but it might improve the chances of it getting returned if someone scans the tag with their phone.
- Having a party? Add an NFC tag to the invitation so all the info is there at the tap of a smartphone, including directions. You get the idea... you're really only constrained by your imagination.

CODE
THE
CLASSICS
VOLUME 1

CODE THE CLASSICS VOLUME 1



Brimble
Crookes
Gillett
Malone
Tracey
Upton?





CODE THE CLASSICS VOLUME 1

This stunning 224-page hardback book not only tells the stories of some of the seminal video games of the 1970s and 1980s, but shows you how to create your own games inspired by them using Python and Pygame Zero, following examples programmed by Raspberry Pi founder Eben Upton.



- *Get game design tips and tricks from the masters*
- *Explore the code listing and find out how they work*
- *Download and play game examples by Eben Upton*
- *Learn how to code your own games with Pygame Zero*

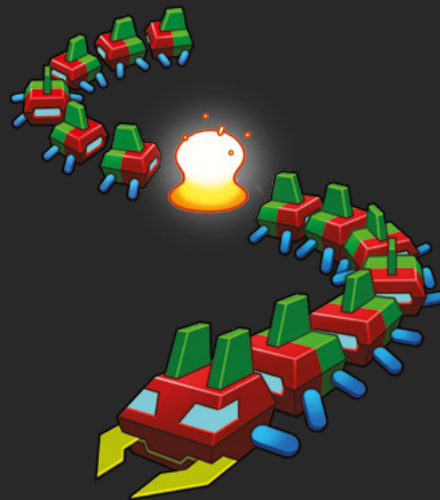

Available now hsmag.cc/store

Beginning electronics with a breadboard and an LED



Stewart Watkiss

MAKER

Also known as Penguin Tutor, Stewart is a maker and YouTuber who loves all things Raspberry Pi and Pico. Author of *Learn Electronics with Raspberry Pi*.

twitter.com/stewartwatkiss

You'll Need

- ▶ Breadboard magpi.cc/breadboardhalf
- ▶ Battery holder magpi.cc/batteryholder
- ▶ LED magpi.cc/diffusedleds
- ▶ 220Ω resistors magpi.cc/220resistors
- ▶ Jumper wires magpi.cc/mmjumpers
- ▶ PCB switch magpi.cc/tactileswitch

Get started with electronic projects using simple components. Find out what makes the electrons flow using a LED light and switch

In this project, you will learn how to create circuits on a breadboard, along with basic information you need to know when starting out with electronics. Find out how to work out which way the LED goes and follow the easy guide to find the right-value resistor. Add the switch and you have the basics of a first circuit.

01 Using a breadboard

A prototyping breadboard is a way of creating electronic circuits by pushing components into the board. Using a breadboard is a great way to learn about electronics. You can use it to create a circuit, swap out some components, and experiment with different values. When you've finished, you pull the components out and they can be reused for your next project. They are designed so that integrated circuits can be plugged into the centre of the board, and you can connect components to the various pins. Most include power rails that run horizontally across the top and bottom, and vertical rails with five holes each – see **Figure 1**.

02 Wire up an LED circuit

You can start by creating a simple circuit using a battery, LED, and resistor. You'll also

need some jumper wires, or solid core wire to create the complete circuit. Avoid stranded wire as that is difficult to insert and the individual strands can break off. The wires for battery packs normally have stranded wires, but hopefully they are tinned, which makes them easy to use. If not, then you may need to push them in using one of the jumper wires.

The first circuit is shown in **Figure 2**.

03 Testing the first circuit

Has the LED lit up? If so great. If not, don't worry: it may be that the LED is the wrong way around. We didn't mention it before, but the LED does need to be connected in a certain direction for it to work. Using a breadboard means that it's easy to experiment: just unplug the LED and insert it with the leads the opposite way around. If the LED still doesn't light, then look for a switch on the battery connector or recheck the wiring.

04 LED direction

When using a breadboard, it's easy to swap components around, but it's not so easy when you create a permanent circuit. There are a few ways to tell which way around an LED needs to go, the easiest (but less reliable) is to look at the length of the leads. The longer lead is normally the anode

Figure 1

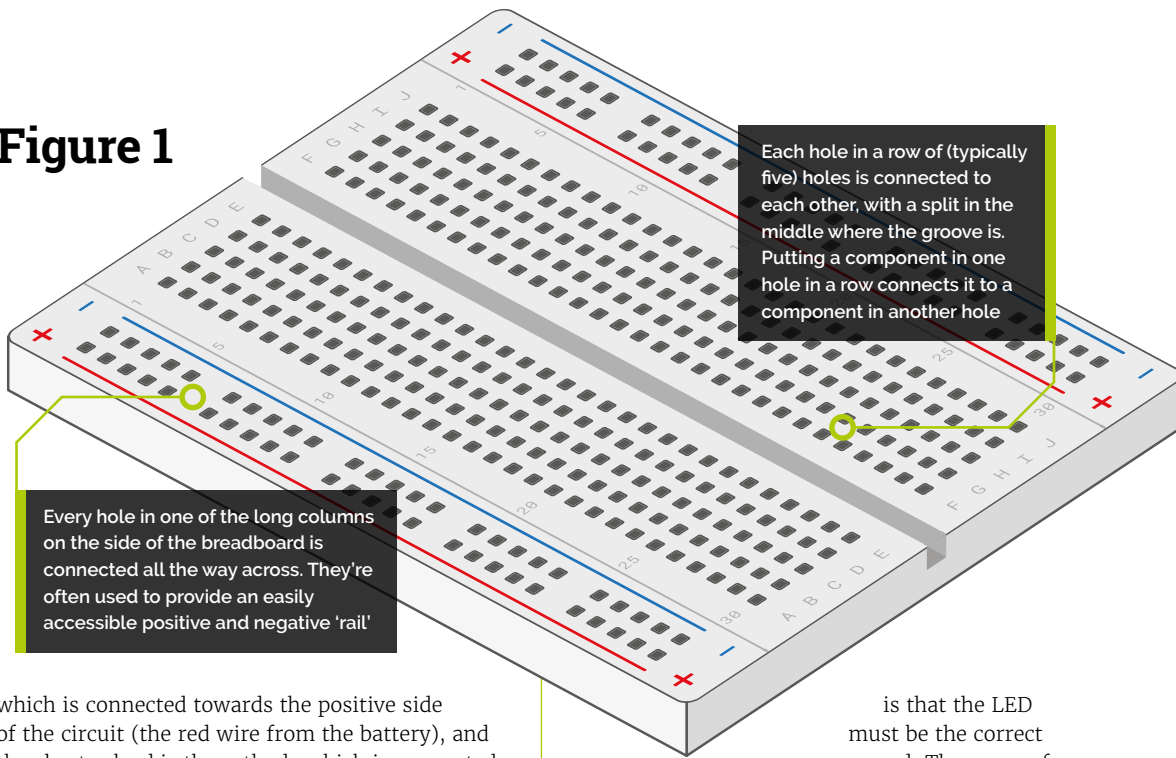

which is connected towards the positive side of the circuit (the red wire from the battery), and the shorter lead is the cathode which is connected towards the negative side of the circuit (the black wire from the battery). A more reliable way of determining the anode and cathode is to look for a flat area on the body of the LED; the flat area normally denotes the cathode (negative) side of the LED.

is that the LED must be the correct way around. The reason for this is that it is a semiconductor device. Semiconductors have special

“ Without the resistor, the LED will allow too much current to flow and burn itself out ”

05 How the circuit works

For an electronic circuit to work, there need to be connections going from the positive terminal of the battery, through the components, and then back to the negative terminal of the battery. This completes a full circuit. The additional factor here

properties that allow them to work as a conductor or an insulator when certain conditions are met. In this case, the LED is a type of diode which acts like a one-way valve. It acts as a conductor when

Figure 2

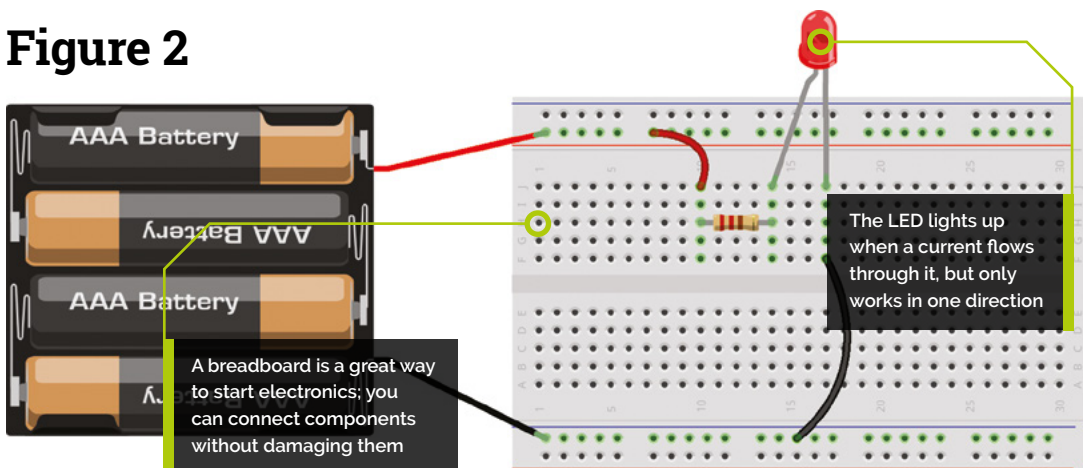

Top Tip

Datasheets are your friend

Datasheets are available for most electronic components. They will provide the information you need to use them in your circuits.

TUTORIAL

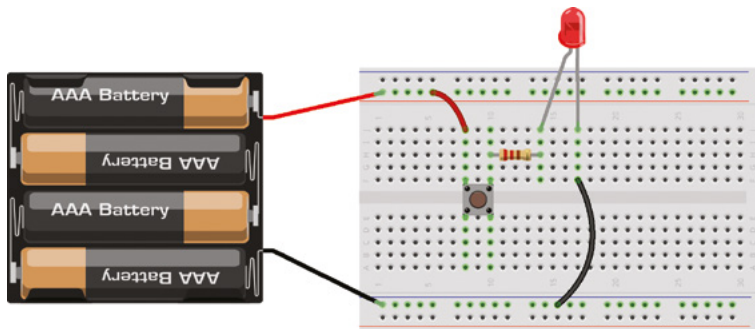

▲ **Figure 7** The updated circuit includes a switch to turn the circuit on and off

in the forward direction and an insulator when in the reverse direction.

06 The resistor

The other component included in the circuit is a resistor. As its name implies, this resists the current around the circuit. This is needed to protect the LED; without the resistor, the LED will allow too much current to flow and burn itself out.

The resistor used in this circuit is 220Ω (ohms), but why do we use this value? To understand how to choose resistors, you need to understand some basic electrical circuit theory. This may sound a bit daunting, but you only need to understand the very basics.

THE MAGPI



This tutorial is from in The MagPi, the official Raspberry Pi magazine. Each issue includes a huge variety of projects, tutorials, tips and tricks to help you get the most out of your Raspberry Pi. Find out more at magpi.cc

LED typical values		
Colour	Voltage	Current
Red	2.0 V	20 mA
Orange	2.0 V	20 mA
Yellow	2.1 V	20 mA
White	3.3 V	20 mA
Green	2.2 V	20 mA
Blue	3.2 V	20 mA

▲ **Figure 4** Typical LED values for voltage and current. Check datasheets for non-standard LEDs

07 Voltage, current, and resistance

The three fundamental measurements of an electrical circuit are voltage, current, and resistance.

Voltage is the amount of electric pressure. Voltage is measured in volts, which uses the symbol V.

Current is the flow of electric charge going through a conductor. It is measured in amperes (normally referred to as amps), which has the symbol A. When used in electronics, the current is normally very small, so is often shown in milliamps (mA) which are thousandths of an amp.

Resistance is how much a material opposes the flow of electric current. It is measured in ohms, denoted by the Greek omega character, Ω . You may also see values in thousands of ohms, known as kilohms (k Ω), or even millions of ohms, known as megaohms (M Ω).

08 Ohm's law

The voltage, current, and resistance are all related to each other. This is all described in Ohm's law. The easiest way to understand this is by using Ohm's law triangle (see **Figure 3**). This has V for the voltage, I for the current, and R for resistance. Cover the letter for the value you want to find, and you have the formula. If you know the current (I) and the resistance (R) but need to know the voltage (V), then cover up the V and it leaves you with $I \times R$. If you want to know the resistor value needed for a specific voltage and current, then cover the letter R and you have $V \div I$.

09 Calculating the resistor voltage and current

To calculate the resistance required, we first need to know the voltage across the resistor. This will be the voltage of the battery, minus the voltage dropped across the LED. The voltage across the LED is specific to the type of LED used, but you can use approximate values based on the typical values.

We are using four AA batteries. These are normally 1.5V per battery, providing a total of 6V. We're using a red LED based on the typical values, which is 2V. This gives $6 - 2$, which is 4V across the resistor.

The current that the LED requires depends upon several factors, including type, size, and brightness.

4-band resistor colour codes			
Colour	Significant figures	Multiplier	Tolerance
Black	0	$\times 10^0$	-
Brown	1	$\times 10^1$	$\pm 1\%$
Red	2	$\times 10^2$	$\pm 2\%$
Orange	3	$\times 10^3$	-
Yellow	4	$\times 10^4$	-
Green	5	$\times 10^5$	$\pm 0.5\%$
Blue	6	$\times 10^6$	$\pm 0.25\%$
Violet	7	$\times 10^7$	$\pm 0.1\%$
Grey	8	$\times 10^8$	$\pm 0.05\%$
White	9	$\times 10^9$	-
Gold	-	$\times 10^{-1}$	$\pm 5\%$
Silver	-	$\times 10^{-2}$	$\pm 10\%$
None	-	-	$\pm 20\%$

▲ **Figure 5** The resistor colour table. For four-band resistors, there are two significant figures, a multiplier, and a tolerance band

We have used 20mA across the table (**Figure 4**), which is a realistic value for a standard 5mm LED.

10 Calculating the resistor value

We now have the voltage across the resistor (4V) and current (20mA), so we can use that to calculate the required resistance. Using the formula $R = V \div I$, we calculate $4 / 0.02 = 200\Omega$.

You may notice that earlier we specified a 220Ω resistor. This was not a mistake. You can indeed use a 200Ω resistor, but they are less commonly available.

“ The current that the LED requires depends upon several factors, including type, size, and brightness ”

Resistors are available in different values, but it would be impossible to have resistors for every calculated value. There are different series of values known as E-series. Your author normally uses E12 series, which provides a reasonable selection of values, with the nearest values being 180Ω or 220Ω. We've chosen the higher value, as

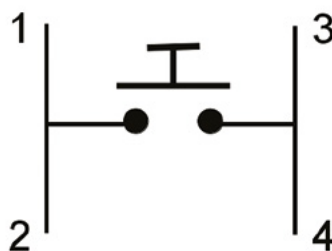

that is safer than risking too high a current. The value we used is 220Ω.



▲ **Figure 6** Many switches have four pins. The pins on each side are connected together, with the switch going between them

11 How to recognise the correct resistor

If you look at the resistors, they don't include the resistance value written on them. Instead, they normally use bands of different colours. A resistor will normally have four or five bands of colour. The four-band variant is the most common, so we will explain that. There is usually a bigger gap between the third and fourth bands so you know in which order to look at the resistor.

The first and second bands denote the first and second significant figure of the value, followed by the third band which is a multiplier (effectively the number of zeroes after the first and second values). For our 220Ω resistor, it will be red (2), red (2), followed by brown ($\times 10$). The fourth band is the tolerance, which for E12 resistors is often gold (5%). See **Figure 5**.



▲ **Figure 3** The Ohm's law triangle, makes it easy to find the formula for calculating resistance, voltage, or current

12 Add a switch

At the moment, the circuit stays on all the time. You can add a switch to the circuit so that it only comes on when this is pressed. This requires a push-to-make switch, which is one which completes the circuit when the switch is pressed.

These switches normally have four pins, but these are wired in two pairs, as shown in **Figure 6**. When you insert these into the breadboard, the pins on the left are connected, as are those on the right. Just remove the jumper wire going to the resistor with a wire from the supply to one side and connect the other side of the switch to the resistor (**Figure 7**). ”

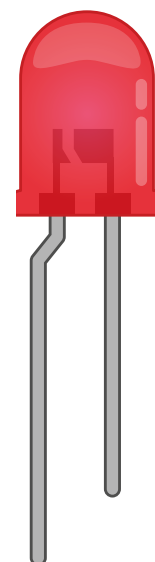

◀ The LED needs to be connected the correct way around. Look for the longer lead (anode) or the flat area (cathode)

Print-in-place

Straight off the print bed and into action



Ben Everard

[@ben_everard](#)

Ben's house is slowly being taken over by 3D printers. He plans to solve this by printing an extension, once he gets enough printers.



One of the most fascinating features of 3D printers is the shapes they can make that wouldn't easily be possible with other manufacturing technologies, and nothing shows this off quite like print-in-place mechanisms.

Perhaps the most obvious example of what's going on is the caged ball. As the cage and ball are printed at the same time, the ball can be entirely in the cage. The same principle can apply to mechanisms, the simplest of which are hinges, such as in bag clips. One cylinder is printed inside the other and you end up with a joint that can hinge, but not come apart.

The major design consideration when doing print-in-place mechanisms is how much clearance they need. Put your parts too close together and they'll stick. Too far apart and the joint will be sloppy. Exactly how far apart will depend on your printing setup and the orientation of the part.

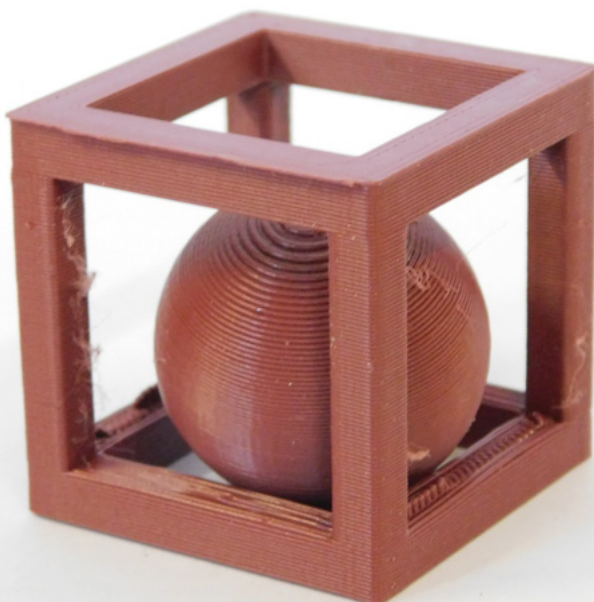

Right

The ball in cage by KIO-Design on Printables shows the basic principles of print-in-place. Two objects that can be printed together, but then can't be separated



Above Our print-in-place catapult has a hinged arm that can fling ping-pong balls

For objects that separate vertically, you can use a test, such as hsmag.cc/ClearanceCheck, to see what your printer can handle. This prints rotating parts with different amounts of clearance. You can then test each part to see which ones rotate, and that's the smallest clearance you can have.

It might seem a bit counter-intuitive that you can also have print-in-place parts that are separated in the Z-axis. After all, you can't print in thin air. However, this can work if you're careful. If there's a small vertical gap, the filament below will support the part above it without actually adhering properly. The final part can need a bit of force to loosen the joint the first time it's used but, after this, it should work fine.

We decided to test out print-in-place designs with one of our favourite hinged mechanisms – the catapult. We wanted the whole thing to print as one piece, requiring just the addition of an elastic band once it comes off the build plate.

There's nothing particularly complex about the catapult design, but we won't go through it all here.

Download the STL file from hsmag.cc/catapultstl if you just want to fire scrunched-up paper across the room, or the FreeCAD file from hsmag.cc/catapult if you want to play with the variables.

You can print it upside down without supports. To make it a super-fast print, use lightning infill (available in PrusaSlicer 2.6). Once you've printed it, you just need to add an elastic band. Loop it



Left ◊ Viewing from the bottom, you can see how the links of the dragon join together

“ You just have to make sure that each piece is printable and that there is a sufficient gap to let the parts move

”

round the bar that holds the two sides together, then hook it onto the end of the arm. Pull the cup back, load it with your ammunition of choice, and fling it in a responsible direction so as not to cause distress or damage (if you ignore those last twelve words, don't blame us). In the FreeCAD design files, the specifications for the print-in-place parts are in the variables spreadsheet. There are options for pivot radius, pivot tolerance, and arm tolerance. The pivot tolerance is the difference between the radius of the solid bar of the pivot and the radius of the hole this goes through. By default it's 1 mm, which gives a very low-friction swing, but you can try dialling it in closer. The arm tolerance is the distance between the arm of the catapult and the slot in the base it sits in. Make it closer and the catapult will be slightly more accurate, but it might add more friction.

As you can see, there really is nothing special about designing print-in-place. You just have to make sure that each piece is printable and that there is a sufficient gap to let the parts move. If you need supports for some parts of your model, you might need to use support blockers in your slicing software to make sure that they don't end up being placed inside the mechanism in such a way that stops them from being removed.

Now that you've seen how print-in-place can work, you can design your own parts. ◻

Below ◻ This print-in-place dragon, by Sunset on Printables, has lots of links that create a very fluid model

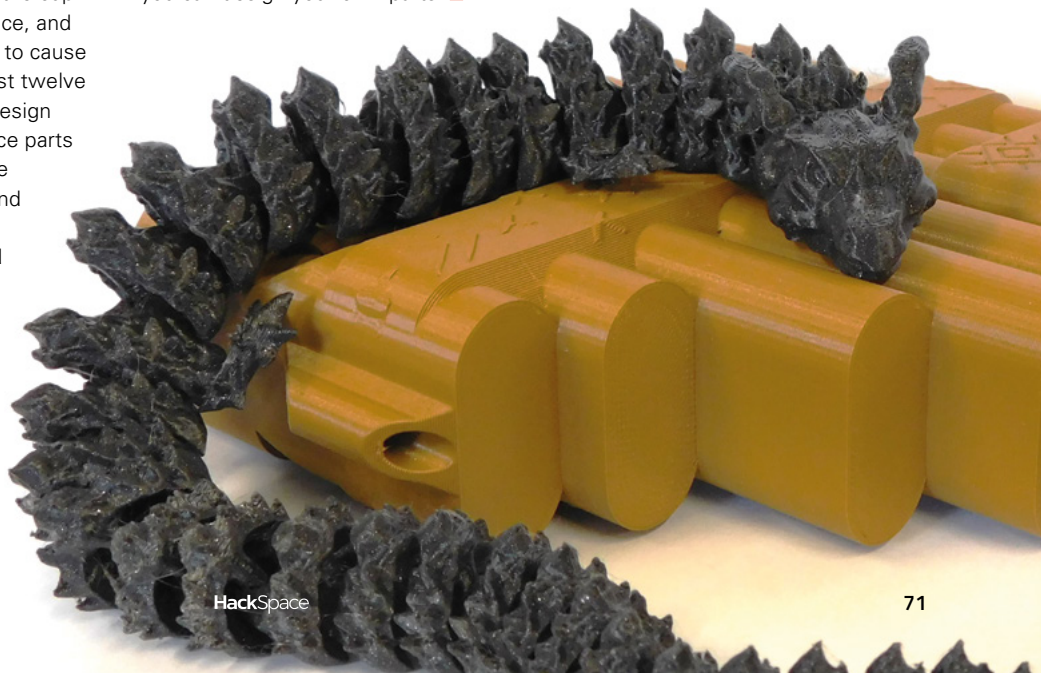

Hands-free lighting

Shine a light on your projects without ever having to flick a switch



Dr Andrew Lewis

Dr Andrew Lewis is a specialist fabricator and maker, and is the owner of the Andrew Lewis Workshop.



Above ♦

The HC-SR04 can give you hands-free control over your lights, but needs enough space to operate without interference. This lighting project pushes the limits of the setup, with tools and a work surface relatively close to the sensors. You could use a laser ToF sensor for more precise detection with less chance of accidental triggering, or you could modify your code to require a close sensor swipe from one of the sensors to 'activate' the regular sensing mode



QUICK TIP

The cone angle of the HC-SR04 ultrasonic sensor means that building a light over a couple of metres will be impractical. For longer lighting runs, try using a VL53L1 laser time of flight (ToF) sensor instead.

Left If you're feeling ambitious, a fourth sensor could be used to control the colour temperature of the lights, to provide a warm or cool working environment

It isn't always easy to turn a light on and off in the workshop. Your hands are covered in oil, the switch is too far away, and speech control only works if you can remember the name of the light you want to control. With a Raspberry Pi Pico, a strip of NeoPixel lights, and some

ultrasonic sensors, you can create a dimmable strip light that only shines where you want it to. In this project, you'll learn how to control NeoPixel LEDs from a Raspberry Pi Pico running MicroPython, and how to use multiple ultrasonic

sensors to detect the position of your hands. To paraphrase Adam Savage, we all need more light in the workshop. This is particularly true as we age. Our lenses become less clear, the parts of the eye that detect contrast changes begin to die off, and the muscles that control our iris become less able to react to changes in light. These changes can affect our daily lives in a number of ways, but most notable is the need for more light when working on fine projects.

The problem with just adding more lights is that you don't always want the light to be everywhere. Badly positioned lighting will shine in your eyes and blind you, rather than help you to see. Constantly turning lights on and off disrupts your flow while you're working, and it isn't always easy to adjust the position

of a light if your hands are covered in oil or wet paint.

The problem with just adding more lights is that you don't always want the light to be everywhere

SWIPE RIGHT TO LIGHT

This project addresses these problems by using three ultrasonic sensors to control a strip

of NeoPixel lights. Two of the sensors are mounted at each end of the strip of lights, and measure the distance to your hands. The remaining sensor is mounted perpendicular to the lights and allows you to adjust the brightness of the light strip. By positioning your hands in the air between the sensors, you can control which area of the light strip will be illuminated, so that you only turn on the areas that you need to use. →

YOU'LL NEED

- ◆ 1 × Raspberry Pi Pico
- ◆ 1 × NeoPixel/WS2812 LED strip
- ◆ 3 × HC-SR04+ ultrasonic sensor
- ◆ MP1584EN DC buck converter, set to output 3.3V
- ◆ 2.5mm panel mount DC power socket
- ◆ Suitable 5V DC power supply (Your requirement will vary depending on NeoPixel length)

TUTORIAL

Right

Connecting the circuit together is not complicated, and pin choices are more to do with convenient positioning of cables than any special features of the Pico

Below

You can mount the light using double-sided foam tape. However, the adhesive used on some LED strips can lose its effectiveness in rooms where the temperature gets very warm or very cold. In these cases, some clips and screws can be a better choice

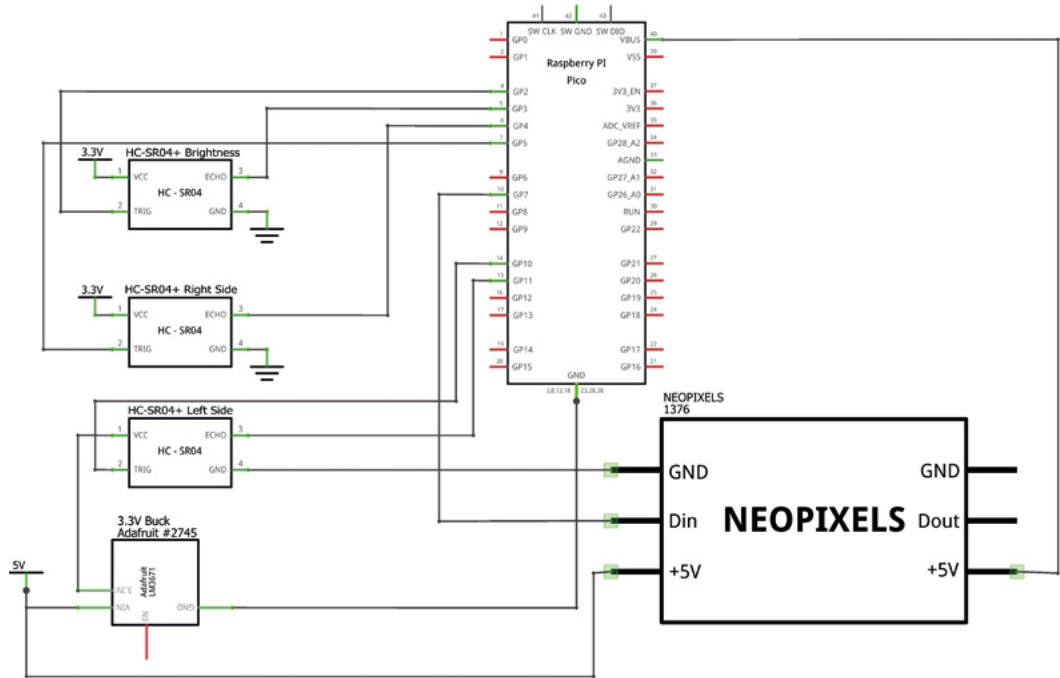

POWER PROBLEMS

NeoPixel strips run from 5V, and they are power-hungry beasts. The more NeoPixel LEDs you have per metre, the more power you are going to have to feed to them to keep them happy. For longer lengths of NeoPixels, you'll need to inject an extra 5V power into the strip every few feet, or your LEDs will start to show the wrong colours and generally misbehave.

If you look at the circuit diagram for this project, you'll see that the LED strips have a capacitor across their power wires. The value of the cap isn't critical, but it's worth realising that it's there to protect the power supply from sharp transients if lots of the LEDs turn on or off at the same time. Without capacitors to buffer the output, it's possible that the power level might even vary enough to reset or crash the Raspberry Pi Pico if it's sharing the same power supply.

While the Raspberry Pi Pico doesn't require much power at all, once you add multiple ultrasonic sensors and a length of LED lights into the equation, you're going to need quite a chunky power supply to keep everything running and, if your NeoPixel strip is over two metres, you should probably think about adding multiple power supplies to keep the LEDs looking at their best. If your lights are on the shorter side, you should be able to get away with using a single power supply for everything.

QUICK TIP

A simpler version of this project could use the ultrasonic sensor input to turn a light or relay on or off using a simple hand gesture.

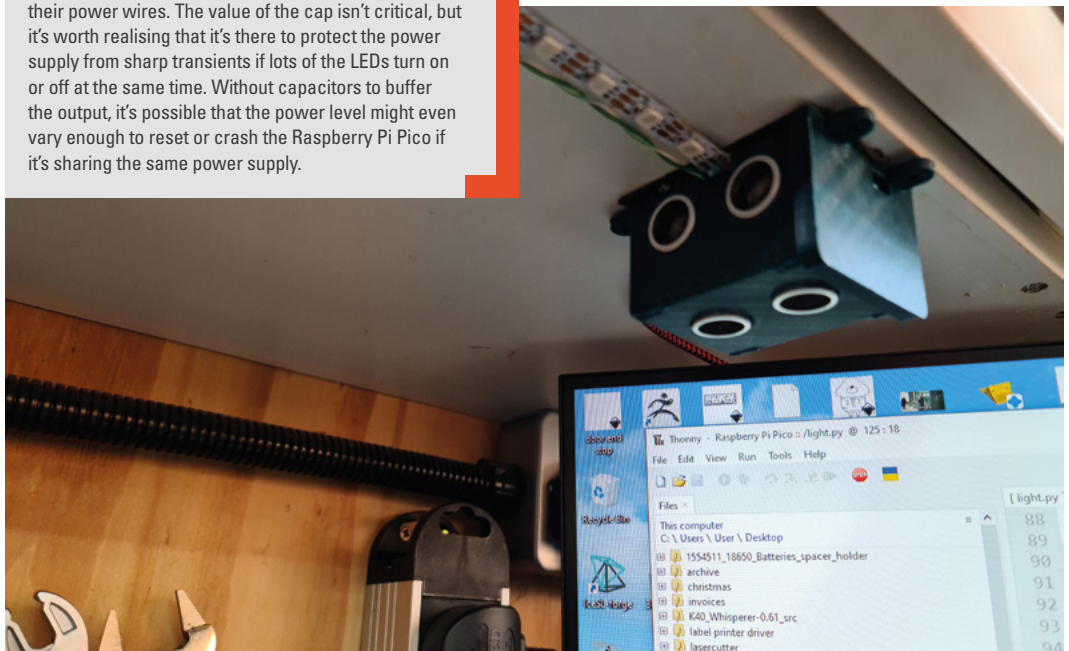

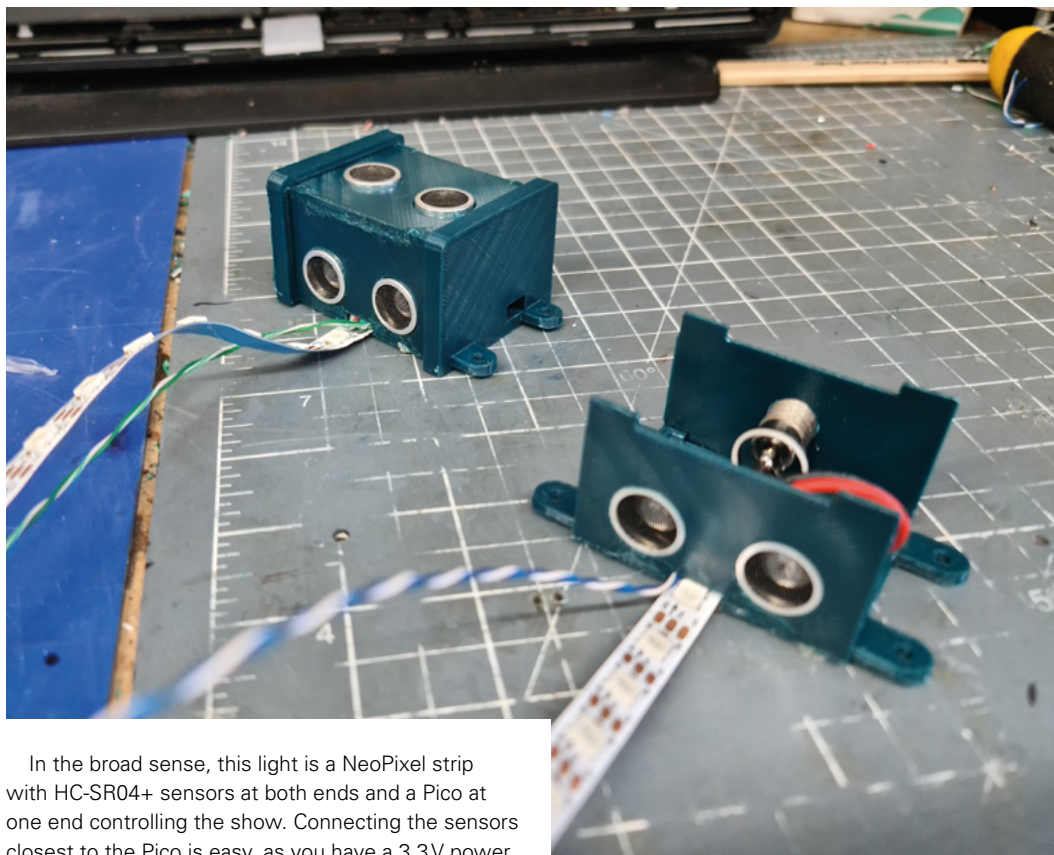

QUICK TIP

If you feel up for a challenge, why not use a Raspberry Pi Pico W, and give the lights some additional Wi-Fi compatibility?

Left ♦ Twisted pair wire will help reduce the possibility of interference over longer cable lengths

In the broad sense, this light is a NeoPixel strip with HC-SR04+ sensors at both ends and a Pico at one end controlling the show. Connecting the sensors closest to the Pico is easy, as you have a 3.3V power connection that you can use built right into the Pico, and the cables between the sensors and the Pico are nice and short. The sensor at the opposite end of the light is a different matter. The sensor is sitting at the far end of the NeoPixel strip, but needs connecting to 3.3V power and the trigger/echo pins need to be connected to the Pico's GPIO pins.

NO MORE OILY SWITCHES

Solving the power connection issue is simple. If the power input for the light is at the far end of the NeoPixel strip, the Pico can use power from the strip itself via the VBUS pin. In this way, the Pico will also function as a step-down voltage converter for the two sensors connected to the 3.3V pins. This leaves the remaining sensor at the opposite end of the cable, which can be connected to a step-down power converter set to produce 3.3V. For the trigger and echo pins, it's advisable to make the connections with twisted pair copper wire to reduce the possibility of interference over the longer length of the wire.

With all of the circuitry complete, you can position your light. Remember, the HC-SR04+ has a 15-degree cone, so the detection area will be quite large, and you'll need to make sure that there are no obstructions in the detection area. If you need a more precise sensor, consider the VL53L1 laser-based ToF sensor instead. □

POTENTIAL PROBLEMS

The most common ultrasonic sensor used by makers is probably the HC-SR04, which has 5V logic. This is a problem for Pico users, since the Pico uses 3.3V logic, and isn't tolerant to 5V signals. One option here is to use a level shifter, like the TXB0108, to act as an intermediary between the sensor and the Pico, ensuring both receive the correct voltages on their signal lines. Alternatively, the slightly more expensive HC-SR04+ is a low-voltage version of the sensor that run directly from 3.3V without needing the level shifter.

The HC-SR04+ has a 15-degree cone. Reading that value from the data sheet might make you think that the effective size of the sensor area increases as the distance from the sensor increases. To put it another way, the further you are from the sensor, the more chance that you'll accidentally wave your hand into the area that the sensor is monitoring. It's actually a bit more complicated than this, because the cone varies between somewhere around 40 degrees and 15 degrees, depending on the distance from the sensor. The practical upshot is that this light can't be positioned somewhere that it's likely to encounter interference from objects statically positioned in or moving through the cone, although things like parallel walls aren't generally a problem because the angle of incidence between the beam and the surface will see the echo reflected away from the sensor.

The next quirk that you need to consider is that you'll be using multiple sensors, two of which will be facing each other. That means you'll need to fire each sensor in sequence and wait for a response before firing the next to avoid the sensors interfering with each other. It's also worth noting that other ultrasonic devices like distance gauges and car parking sensors could also interfere with the sensors used in the lights.

The most unexpected issue encountered with these sensors is that flexing the PCB can shift the position of the sensors, which affects the distance reading slightly and can, in some cases, cause an object not to be detected after a certain distance. Making sure the board isn't under any physical stress is important to maintain accuracy.

FROM THE MAKERS OF *The MagPi* THE OFFICIAL RASPBERRY PI MAGAZINE

NEW
2022
UPDATE

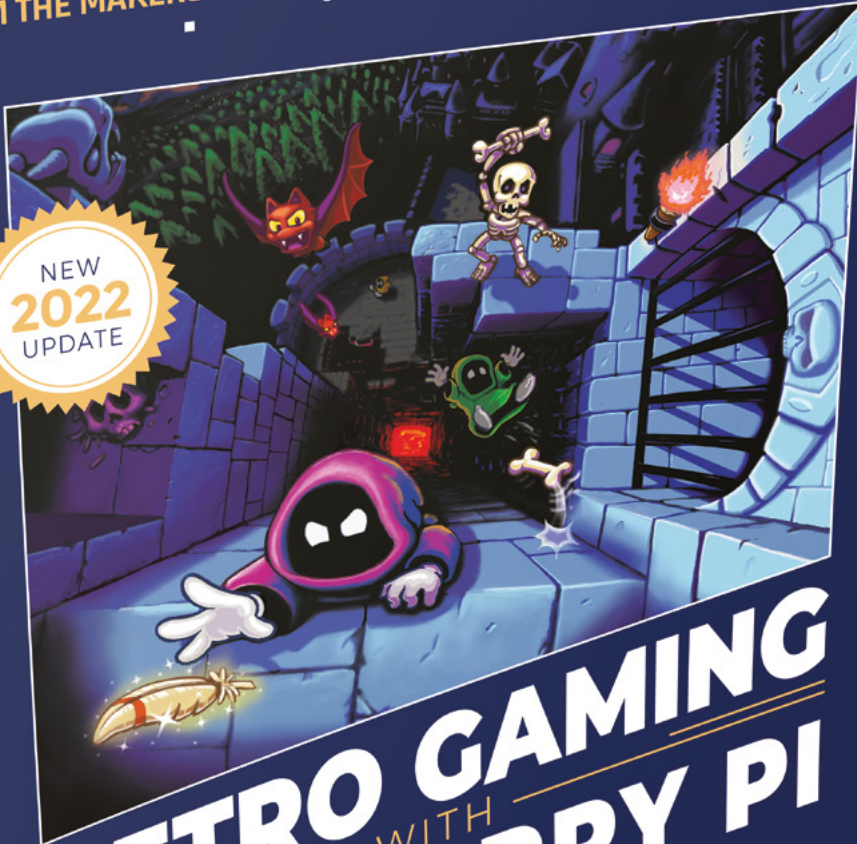

**PLAY
& CODE
GAMES!**

RETRO GAMING WITH RASPBERRY PI

2ND EDITION

164 PAGES OF
VIDEO GAME PROJECTS

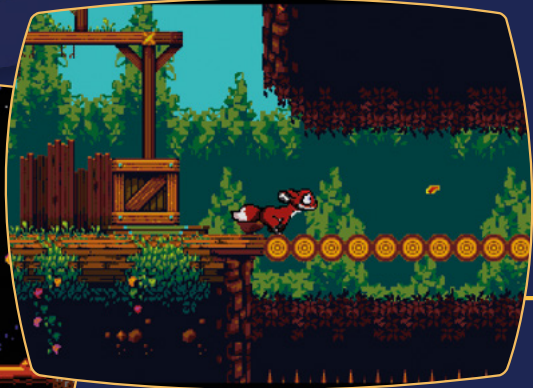

RETRO GAMING

WITH

RASPBERRY PI

2ND EDITION

Retro Gaming with Raspberry Pi shows you how to set up a Raspberry Pi to play classic games. Build your own games console or full-size arcade cabinet, install emulation software and download classic arcade games with our step-by-step guides. Want to make games? Learn how to code your own with Python and Pygame Zero.

- *Set up Raspberry Pi for retro gaming*
- *Emulate classic computers and consoles*
- *Learn to code your own retro-style games*
- *Build a console, handheld, and full-size arcade machine*



BUY ONLINE: magpi.cc/store

Rad your ride with Pico

Turn a manual scooter into a motorised monster



Dr Andrew Lewis

Dr Andrew Lewis is a specialist fabricator and maker, and is the owner of the Andrew Lewis Workshop.

In the first part of this series, you discovered how motor controllers and throttle controllers can be used by a Raspberry Pi Pico to control an electric motor on a scooter. In this article, you will find out how to make custom battery packs

for your scooter and add some features that will keep you safe while you ride.

Electric motors have high torque, but without adequate power to supply the motor you will have a very disappointing ride. Twenty years ago, a lead-acid or nickel-cadmium battery would have been the most appropriate choice for powering an electric bike. Now, lithium polymer (LiPo) batteries are a much better alternative. As you probably know, LiPo batteries are not as friendly as other types of battery, and will sometimes indicate their opposition

to mistreatment by swelling up with explosive gas or turning themselves into a raging inferno. Discharging a LiPo battery too deeply can permanently damage it, and so will overheating it. All of these constraints mean that creating your battery pack requires some careful planning.

To begin with, you'll have to decide the basic voltage that you need your scooter battery to provide. With a charge level that hovers between 3.7V to 4.2V per cell, a 24V motor should work with six cells in series. You will also need to consider the continuous discharge current of the batteries that you use. Some 18650 batteries only discharge at 1C (C being the rate at which the battery can be charged or discharged, such that a fully charged 2500mAh 1C battery would provide a maximum of 2500mA for one hour). To power a scooter motor, you will need a battery with a 10A or even 20A continuous discharge rate, depending on the motor that you are using.

Now that you know how many batteries you need, and have the right type, you'll need some method of using them safely. You will need a battery protection board. Battery protection boards allow you to easily build your own battery packs from 18650 cells, and look after all of the difficult jobs



Above Here, you can see 18650 cells in a 3D-printed holder, and a battery protection board. When they are welded together into a complete battery, they will be encased in plastic to protect them. An additional rubber shim will be placed behind the protection board to make sure that no short circuits can occur

BE AWARE

As stated in part one of this tutorial (in HackSpace #66, hsmag.cc/issue66), you're not going to be able to ride a scooter like this on the open road, on a footpath, or even in a bike lane in the UK. Electric scooters are in a class of vehicle known as 'powered transporters', which makes them the same as a car or a motorcycle in the eyes of the law. Scooters don't have some of the features needed to pass an MOT test, so they are not legal to ride on the road or the pavement. You risk fines of several hundred pounds and the loss of your driving licence if you do ride them in public. The government are developing new standards and adjustments that will eventually make electronic scooters legal in the UK, but they are not legal yet.

TAKE CARE



Scooters – whether powered or not – carry some risks. It's your responsibility to make sure the scooter doesn't go faster than you personally feel comfortable with. You are also responsible for ensuring that any chassis modifications you make are sufficiently strong. We strongly recommend you err on the side of caution as your decisions on both these risks could impact not just you, but the people around you.



Left

The battery and motor controller for this scooter are mounted at the front. The battery is removable, and can be swapped out in a couple of seconds. Batteries are charged using an identical battery holder to the one mounted at the front of the bike, except the charger is connected to a bench power supply

“ **Battery protection boards allow you to easily build your own battery packs from 18650 cells** ”

like preventing excessive discharge, monitoring the battery voltages, and recharging the batteries safely. Protection boards are usually rated by current and have an S value associated with them. The S value tells you how many batteries a board is designed to protect. For example, a 24V 15A 6S board would have six 18650 cells connected to it, giving you a 24V battery with a maximum discharge rate of 15A. The battery protection board connects to each cell individually so that it can keep a close eye on what's happening. That means a 6S battery protection board will have the cells connected →

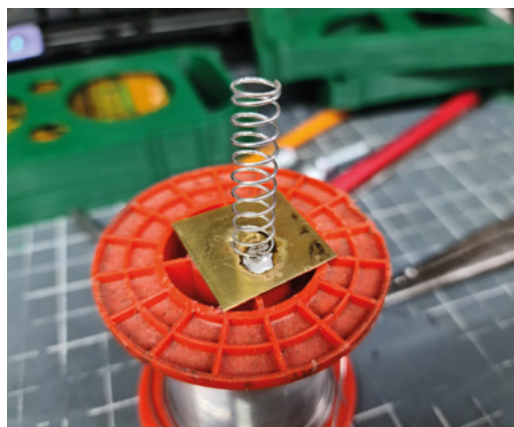

Above

If you're going to use a spring to power a device, make sure that it's thick enough to handle the power it will be transferring. If it isn't, either add multiple springs, or copper tabs with thicker braided wire at the top and bottom of the spring. Overheating power connectors can cause fires

QUICK TIP

Modern LiPo batteries have a minimum safe voltage of around 2.5V. If you allow the battery to drop below 2.5V, it may never recharge or work properly ever again.

TUTORIAL

QUICK TIP

Battery protection boards don't usually include temperature protection. To protect your batteries against overheating, you should consider placing a low-temperature (possibly +85°C 40A, 28V, as an example) thermal fuse in the battery pack. The thermal fuse will break the circuit if the battery heats up too much.

Right

Keep your cells neat using plastic cell supports, and when you're done with your spot welding, give everything a nice generous coating of Kapton tape before the cells go into their final home (the 3D-printed removable pack, in the case of this scooter conversion)



You do not want any opportunity for the system to short out and cause a fire

BATTERY WELDER

One thing that 18650 batteries are particularly sensitive to is heat, which can make connecting them together a bit of a problem. The sort of temperatures needed to melt solder are too high for an 18650 battery to endure, and attempting to solder cells together will end with either a completely dead battery, or one that performs far below its expected rating. To join 18650 cells together, you really need to use a battery welder. The battery welder is a miniature spot welder that allows you to join nickel strips to batteries (and PCBs) without excessively heating the battery. The power used to spot-weld the metal strips is tightly focused, and dissipates very quickly before it can cause damage by overheating the cells. Battery welders are relatively inexpensive, and are worth purchasing if you have any power tools that might need battery packs replacing in the future. They often come with a selection of nickel strips to suit different battery needs.

QUICK TIP

It's best to think about using removable battery packs if you are going to ride your scooter regularly. Having to wait while the hard-wired batteries recharge is not ideal.

together in series with an extra connection between each cell for a total of seven connections, and two other connections that serve as the input/output of the battery pack.

What's good for your motor isn't necessarily good for your controller, and trying to power a Raspberry Pi Pico directly from 24V will release plumes of magic smoke into the air. You need to add a small buck converter that takes the 24V battery power and reduces it down to 3.3V for the Pico and the logic side of the motor controller. Most importantly, you need to add a fuse to your scooter, immediately after the battery connection. You do not want any opportunity for the system to short out and cause a fire. □

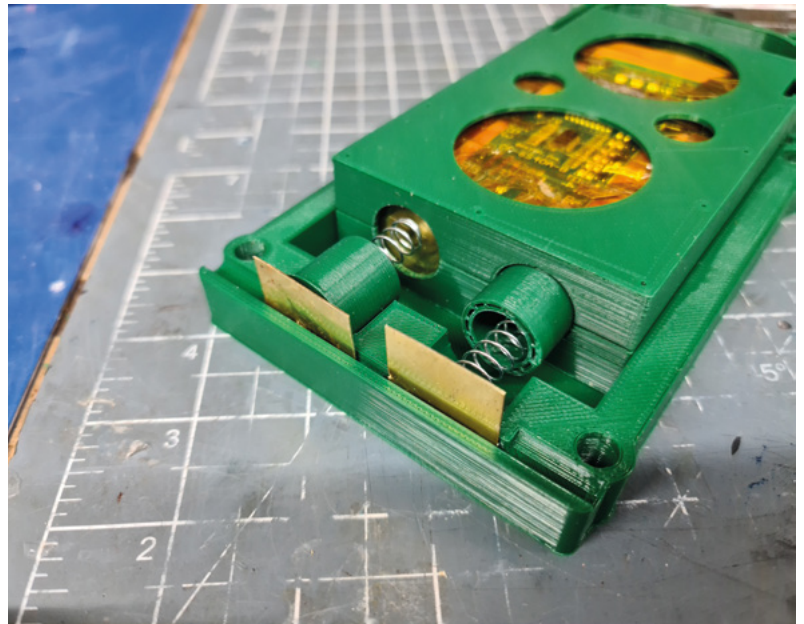

Above ♦

The box below the battery houses the motor controller, fuse, and DC-DC buck converter that reduces the 24V battery power down to 3.3V for the Pico and motor controller logic. The key in the side can be removed to disconnect the enable signal for the motor. This isn't actually that important, since if you were leaving the scooter, you'd probably remove the battery anyway



Above ♦

If you are making your own battery packs rather than using the 3D model files provided with this article, you need to make sure it's impossible to connect your batteries in reverse. Providing reverse voltage to the buck converter would probably kill every single component in the scooter, and cause a great deal of swearing

SPI DISPLAY

Although it isn't strictly necessary, it's quite nice to have a display on your scooter to tell you how much power you're applying at the throttle, and optionally monitor your battery levels using a potential divider connected to one of the analogue inputs on the Pico. A round ST7789 SPI display can be connected to the Pico using the instructions at hsmag.cc/SPIDisplay, with some example code included with this project to show how it can be used as a simple power gauge.

HackSpace mag experiments: ChatGPT

We let an AI chatbot do our 3D design for us



Ben Everard

@ben_everard

Ben's house is slowly being taken over by 3D printers. He plans to solve this by printing an extension, once he gets enough printers.

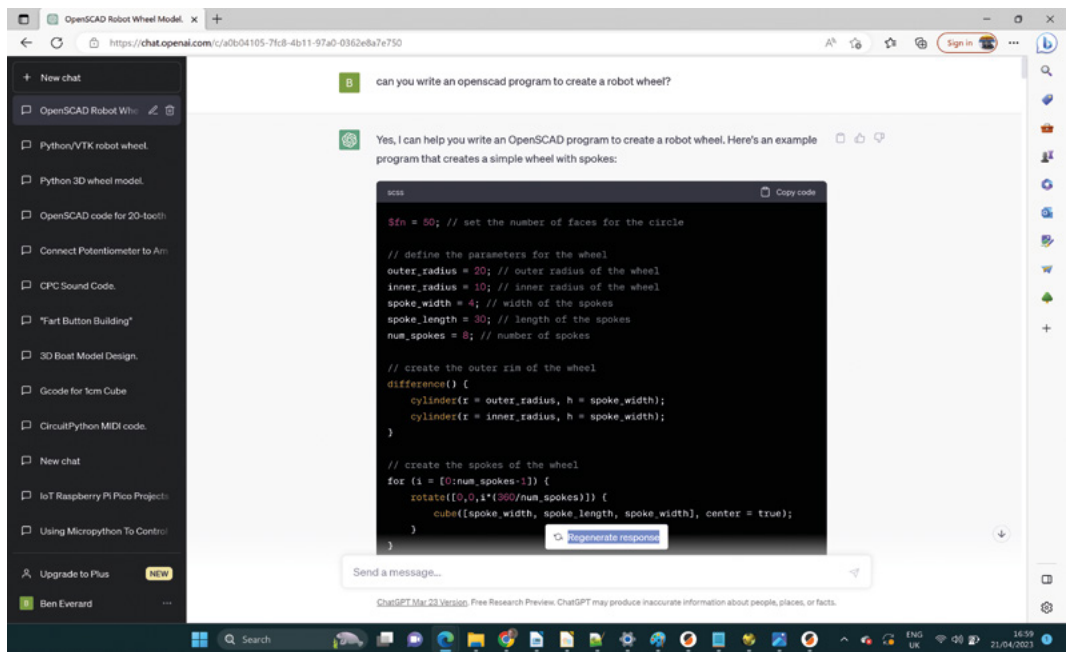

ChatGPT is the current darling of the AI world. It can produce impressively useful responses to many questions, and some people are finding it useful for writing programming code. Using the OpenSCAD 3D modeller, 3D designs are just code, so we decided to put it to the test and try to get it to design something for us. We wanted something not entirely trivial, but also not something so complex that it had no chance of understanding it. We decided on a simple buggy: four wheels, two axles, and a body. To give it the best possible chance, we decided to get it to design these parts individually.

While this author does have some experience with OpenSCAD, that was several years ago, and he's forgotten almost all of the little he did know. He tried to get ChatGPT to write the entirety of the code. Each time, just copying and pasting the chatbot's responses into an OpenSCAD session and rendering the code.

The first thing we've learned about prompt engineering is that you get the best results by keeping everything simple and building up from small parts. To help with this, we decided that we'd design the wheels, axles, and body of the buggy separately.

The full process for getting everything designed and working properly was quite long, so here's an edited transcript of how it went. We started with the

Above You can sign up for a free account and design your own monstrosities at chat.openai.com

prompt: 'Can you write an OpenSCAD program to create a robot wheel?'

ChatGPT came back with the following code:

```
$fn = 50; // set the number of faces for the circle

// define the parameters for the wheel
outer_radius = 20; // outer radius of the wheel
inner_radius = 10; // inner radius of the wheel
spoke_width = 4; // width of the spokes
spoke_length = 30; // length of the spokes
num_spokes = 8; // number of spokes

// create the outer rim of the wheel
difference() {
    cylinder(r = outer_radius, h = spoke_width);
    cylinder(r = inner_radius, h = spoke_width);
}

// create the spokes of the wheel
for (i = [0:num_spokes-1]) {
    rotate([0,0,i*(360/num_spokes)]) {
        cube([spoke_width, spoke_length, spoke_width], center = true);
    }
}
```

This does produce a working wheel. It's got spokes. We didn't ask for spokes, but then we didn't specify 'no spokes' either, so I suppose this is OK, if a little over-complicated. There's no way to attach an axle, so the next step is to ask for an axle hole, and ChatGPT replied with the following code:

```
$fn = 50; // set the number of faces for the circle

// define the parameters for the wheel
outer_radius = 20; // outer radius of the wheel
inner_radius = 10; // inner radius of the wheel
spoke_width = 4; // width of the spokes
spoke_length = 30; // length of the spokes
num_spokes = 8; // number of spokes
axle_hole_radius = 10; // radius of the axle hole

// create the outer rim of the wheel
difference() {
    cylinder(r = outer_radius, h = spoke_width);
    cylinder(r = inner_radius, h = spoke_width);

    // subtract the axle hole cylinder from the center of the wheel
    translate([0, 0, -1]) {
        cylinder(r = axle_hole_radius, h = spoke_width+2);
    }
}
```

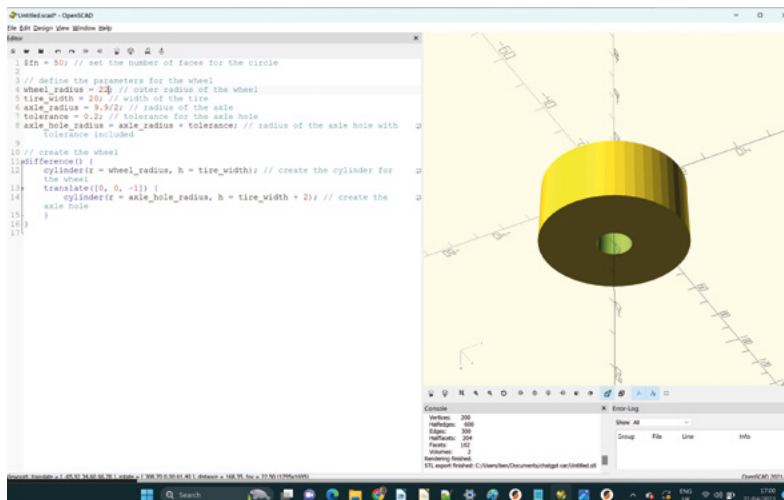

```
}
}

// create the spokes of the wheel
for (i = [0:num_spokes-1]) {
    rotate([0,0,i*(360/num_spokes)]) {
        cube([spoke_width, spoke_length, spoke_width], center = true);
    }
}
```

Above In OpenSCAD, 3D models are defined by code, so a chatbot should be the perfect AI to make them

This is obviously flawed. The problem is that the axle hole is subtracted from the rim of the wheel rather than the centre of the spokes, which is where the axle will actually meet the wheel. We had a bit of back and forth with ChatGPT trying to get it to solve the problem, but it seemed beyond its capabilities. In the end, we resorted to a simpler prompt: 'Can you create a robot wheel with a 10 mm axle hole and without spokes?'

The result was deceptive:

```
$fn = 50; // set the number of faces for the circle

// define the parameters for the wheel
outer_radius = 20; // outer radius of the wheel
inner_radius = 10; // inner radius of the wheel
axle_hole_radius = 5; // radius of the axle hole

// create the outer rim of the wheel
difference() {
    cylinder(r = outer_radius, h = 10);
    cylinder(r = inner_radius, h = 10);

    // subtract the axle hole cylinder from the center of the wheel
    translate([0, 0, -1]) {
        cylinder(r = axle_hole_radius, h = 12);
    }
}
```

TUTORIAL

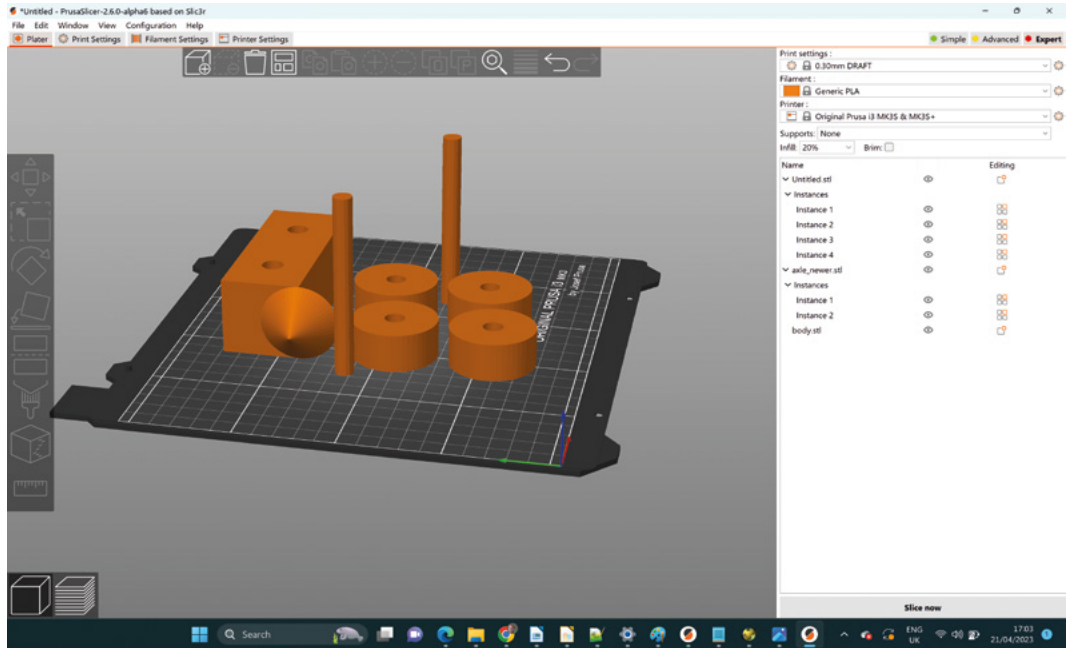

Right With all the parts sliced, it's ready to print

At first glance we thought this had worked, but it's made the hole in the middle far too large. For some reason, it's drawn a wheel rim rather than a complete wheel.

The prompt, 'I don't think we need an inner radius. You can just have a cylinder the size of the outer radius with the axle hole cut out', created a working wheel, but we needed to add: 'Sure! To add a tolerance of 0.2mm to the axle radius, can we modify the `axle_hole_radius` variable to include the tolerance?' to get the final code of:

```
$fn = 50; // set the number of faces for the circle

// define the parameters for the wheel
wheel_radius = 50; // outer radius of the wheel
tire_width = 20; // width of the tire
axle_radius = 9.9/2; // radius of the axle
tolerance = 0.2; // tolerance for the axle hole
axle_hole_radius = axle_radius + tolerance; //
radius of the axle hole with tolerance included

// create the wheel
difference() {
  cylinder(r = wheel_radius, h = tire_width); //
create the cylinder for the wheel
  translate([0, 0, -1]) {
    cylinder(r = axle_hole_radius, h = tire_
width + 2); // create the axle hole
  }
}
```

At this point, you've probably realised that getting ChatGPT to design a cylinder with a hole in it is far more work than just designing a cylinder with a hole in

it. This is definitely true. At almost any skill level, you'll find it easier to just use a CAD tool. However, at some point this is going to change. It might be in the near future, or it might take longer, but eventually you're going to be able to describe a problem to a computer and it's going to design a part for you.

People talk about how 3D printing will revolutionise manufacturing, and while it's had a pretty big effect, it's not hit the mainstream – the reason being it is hard to design things. OK, hard is probably the wrong word, but it's a particular skill that takes time to learn. When AI can take on some of these challenges, having a 3D printer at home becomes an attractive option to a lot more people. We are, however, getting ahead of ourselves. Let's take a step back and see how we get on with the rest of the vehicle.

Perhaps the most confusing part of the build came with the axle. This should just be a cylinder of the appropriate length, and while it was pretty straightforward to get ChatGPT to create an axle at the correct length, the code rendered nothing. On close inspection, we saw the problem:

```
// define the parameters for the axle
axle_radius = 4.9; // radius of the axle
tolerance = 0.2; // tolerance for the axle hole
axle_length = body_width + 2 * tire_width + 5; //
length of the axle

// create the axle
difference() {
  cylinder(r = axle_radius, h = axle_length); //
create the cylinder for the axle
  translate([0, 0, -1]) {
```

```

        cylinder(r = axle_radius + tolerance, h =
axle_length + 2); // create the axle hole
    }
}

```

ChatGPT inexplicably added an axle hole to the axle, which has removed the entire axle. Fortunately, we rectified it with: 'The axle doesn't need an axle hole'.

That's the wheels and axle sorted. Let's try and generate the body. We started with the prompt: 'Can you write OpenSCAD code for the body of a robot buggy with holes for two axles, each hole with a radius of 5.5mm?'. And it did, however, it was a particularly uninspiring rectangular block. We gave it the feedback: 'Can you make the front of the buggy more aerodynamic?' It responded with:

```

$fn = 50; // set the number of faces for the
circle

// define the parameters for the buggy body
body_length = 100; // length of the buggy body
body_width = 60; // width of the buggy body
body_height = 40; // height of the buggy body
axle_radius = 5.5; // radius of the axle holes

// create the buggy body with axle holes and an
aerodynamic front
difference() {
    union() {
        // create the aerodynamic front
        translate([0, 0, body_height/2]) {
            cylinder(r1 = body_width/2, r2 = 0, h
= body_height/2);
        }
        cube([body_length, body_width, body_
height/2]); // create the main body

        // create the axle holes
        translate([body_length/4, body_width/2,
0]) {
            cylinder(r = axle_radius, h =
body_height);
        }
        translate([3*body_length/4, body_
width/2, 0]) {
            cylinder(r = axle_radius, h =
body_height);
        }
    }
}

```

This adds a cone slightly off-centre to the buggy.

At this point, we've got the basics of our buggy sorted. We changed the sizes a little (by directing

ChatGPT on what to do). There are some things that ChatGPT seemed to find really easy (like understanding how long to make the axle), and some things it really struggled with. We've run a few experiments now, and we think there are two things that ChatGPT, in its present state, doesn't seem to understand (if 'understand' is even the right word here):

- **Additive structures and subtractive structures.** If you ask it to make a hole in an object, you'll often find a cylinder added, and likewise, it created a 'hole' around our entire axis.

- **Rotation and translation in 3D space.**

In this example, you can see that the cone on the front of the buggy is clearly not in the right place. To be honest, we find it quite endearing where it is. When we've tried more complex objects, this is always the sticking point.

ChatGPT is clearly not ready for complex 3D design just yet, but it can do basic OpenSCAD code and create functional objects. We didn't correct any syntax or fix any errors; we only ever provided feedback on design. ChatGPT (and other similar large language models) is only going to get better from here. How soon these improvements will affect its ability to work with three dimensions we don't yet know, but we'll continue trying our buggy test with new models and will report back as things change. □

Below ♦
If you really want to, you can download your own ChatGPT car from hsmag.cc/ChatGPT-car

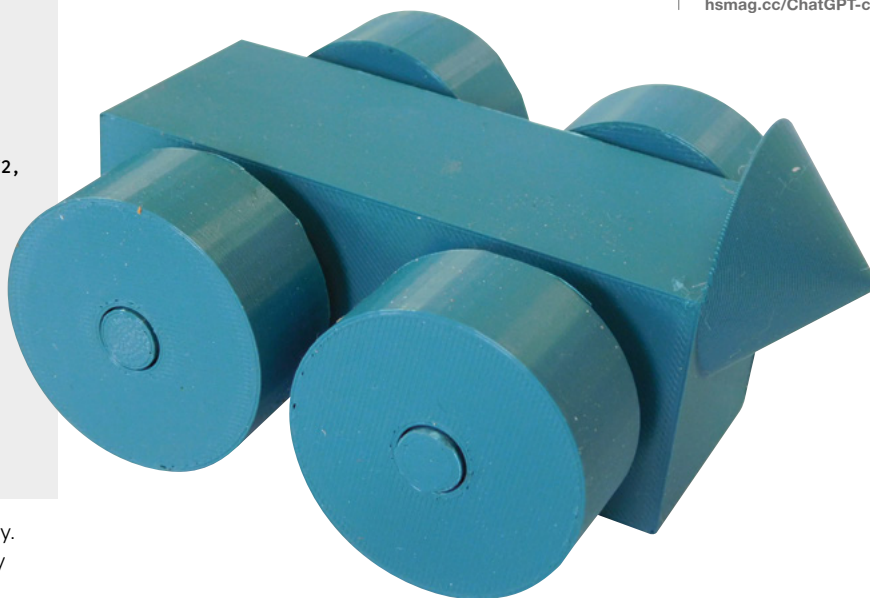

DON'T MISS THE **BRAND NEW** ISSUE!



SUBSCRIBE
FOR JUST
£10!

- ▶ **THREE!** issues of The MagPi
- ▶ **FREE!** Raspberry Pi Pico W
- ▶ **FREE!** delivery to your door

+ FREE
RASPBERRY PI
PICO W*

Three issues and free Pico W for £10 is a UK-only offer. Free Pico W is included with a 12-month subscription in USA, Europe and Rest of World. Not included with renewals. Offer subject to change or withdrawal at any time.



magpi.cc/subscribe

FIELD TEST

HACK | MAKE | BUILD | CREATE

Hacker gear poked, prodded, taken apart, and investigated

PG
94

PICO OSCILLOSCOPE

Test your circuits with this
Pico-based board



PG
96

HOVER BOARD

We are very nearly living
in the future

PG
88

BEST OF BREED

Let's get gardening

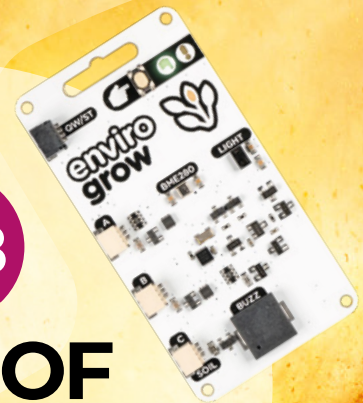

Spring is here! Time to deploy the sensors!

BEST OF BREED

ONLY THE
BEST

Spring is here! Time to deploy the sensors!

A collection of electronics for outdoor remote sensing

By Marc de Vinck

 @devinck

I've covered gardening-related electronics a few times, including wireless sensors, and a host of outdoor-related devices.

And since spring is here, it made me think it's time to look at the possibilities of remote sensing again. I have always wanted to bring a little IoT to my own garden, and hopefully this is the year I do implement some kind of electronics. The past few years have been difficult to tackle that project since components, especially microcontrollers, have been difficult to come by, but that's finally changing. You can source microcontrollers and some single-board computers of various flavours at most of the online shops, and even a few brick-and-mortar retail shops. And I'm seeing new sensors being made available every week that would be perfect for remote monitoring.

Even as I write this article, I can hear the birds chirping outside, and I have a view of a very sad-looking garden that is just starting to show signs of life after its winter hibernation. I'd like to start gathering data, like sun exposure, moisture levels, and possibly even a camera to catch any critters raiding the tomatoes. So that's where this Best of Breed comes into play. I'll be looking at a few things that I'd like to add to my garden this summer to help me go from a boring plot of land to one that can start to speak to me about its needs.



Witty Pi 4 vs Adafruit Feather RP2040 with RFM95 LoRa Radio

UUGEAR ◆ \$27.63 | hsmag.cc/WittyPi4

ADAFRUIT ◆ \$29.95 | adafruit.com/product/5714

The Witty Pi 4 from UUGear is a great solution for all your Raspberry Pi timing, scheduling, and power management needs. No longer will you need to worry about the accuracy of your Raspberry Pi clock thanks to the on-board real-time clock and temperature sensor that allows for additional accuracy and temperature compensation. And anyone who has worked with the Raspberry Pi knows about power management and the relatively difficult nature of powering your Raspberry Pi on or off, and this is where the Witty Pi really shines.

Unlike a microcontroller that you simply power-off, you need to go through a powering-off sequence with your Raspberry Pi, similar to your desktop computer. And the Witty Pi can do that too! Now your Raspberry Pi can shut down and only wake up when needed, saving lots of power. If you have a remote monitoring project, or one that runs off battery power, the Witty Pi should be something to consider adding to the build.

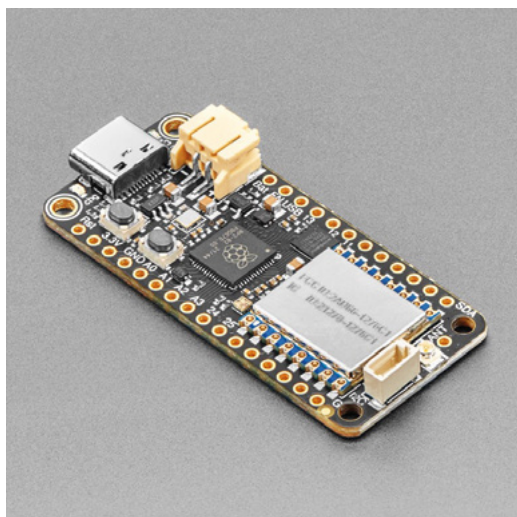
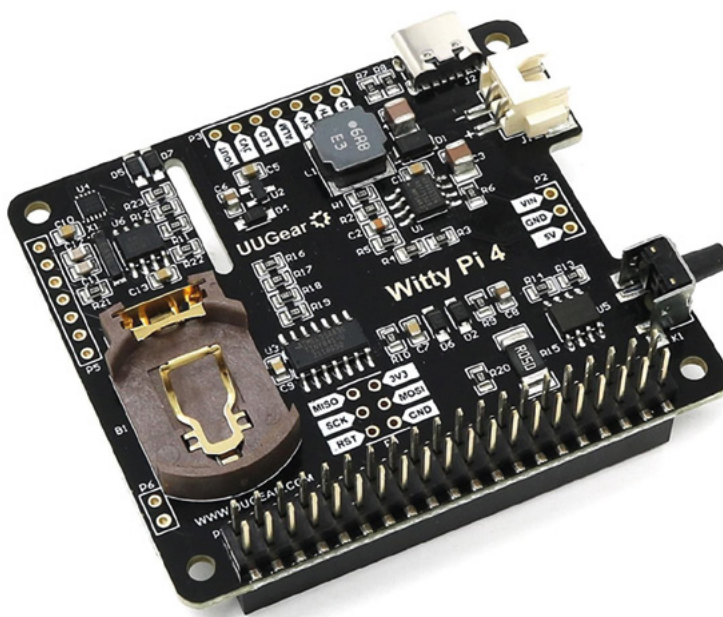

The Adafruit Feather RP2040 RFM95 LoRa Radio board, aka 'RadioFruits', is Adafruit's take on a microcontroller with integrated long-range (LoRa) packet radio transceiver, along with a built-in USB and battery charging system. This is the perfect microcontroller board for creating wireless sensors that have a longer range and require less power than other wireless solutions like Bluetooth.

The board features an RP2040 chip running at 133MHz, the same as you can find on a Raspberry Pi Pico. You also get a generous 8MB of on-board QSPI flash and 264kB of RAM, plus on-board RGB LED, STEMMA QT connector, and lots of GPIO pins. Between the on-board battery management, LoRa radio, and RP2040, it would be hard to beat this little board for creating an outdoor sensor network. →

VERDICT

Witty Pi 4

Great addition to a Raspberry Pi.

9/10

Adafruit Feather RP2040 with RFM95 LoRa Radio

Simple long-range sensing.

10/10

Spring is here! Time to deploy the sensors!

BEST OF BREED

M5Stack PoE Camera with Wi-Fi (OV2640)

PIMORONI [£39.90](#) | hsmag.cc/M5Stack

The PoECAM-W is an open-source and programmable camera that integrates PoE (power over Ethernet) and Wi-Fi giving you plenty of connectivity options. The brain of the product is an

ESP32 board with an integrated webcam and W5500-embedded Ethernet controller. You get a 2-megapixel image sensor, 8MB PSRAM, and 16MB flash large memory.

This could be a good addition for monitoring your outdoor space for pesky intruders, capturing time-lapse videos of the growing season, or just seeing what's going on outside. It's easy to deploy since you can program it via the Arduino IDE or ESP-IDF. And, of course, you must consider how you will make it waterproof, but that could be as simple as mounting it to the inside of a window in your house or shed.



VERDICT

M5Stack PoE Camera with Wi-Fi (OV2640)

The perfect compact camera.

10/10

WITTY PI 4 MINI

UUGEAR [\\$18.42](#)

hsmag.cc/WittyPi4Mini

Just like its big sibling, the Witty Pi 4 Mini is a great addition to your Raspberry Pi, but in a smaller package and with fewer options. The Witty Pi adds a real-time clock with power management to your Raspberry Pi. It can control your Raspberry Pi's on/off sequence, greatly reducing its power usage. If you've worked with a Raspberry Pi before, you know the challenges of power management, and this board does a great job!

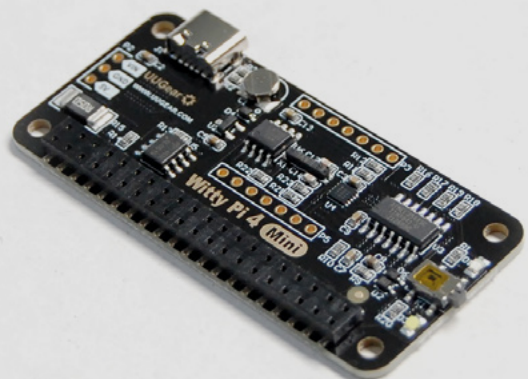

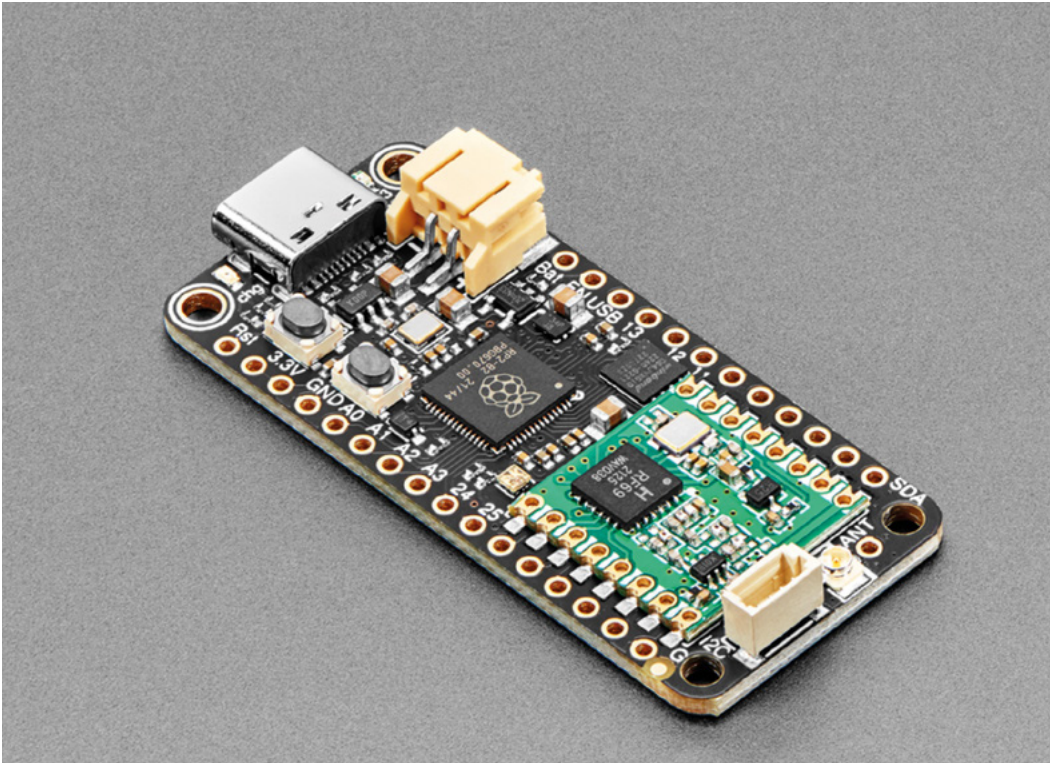

Adafruit Feather RP2040 RFM69 Packet Radio

Left ♦
Remotely control
your garden

ADAFRUIT ♦ \$19.95 | adafruit.com/product/5712

The Adafruit Feather RP2040 RFM69 board is another board Adafruit lovingly refer to as part of its 'RadioFruits' line of microcontrollers.

The board is very similar to the RP2040 with LoRa, but this one features an RFM69 Packet Radio (868 or 915MHz). It's great for sending packets of data between different boards featuring the same type of radio. You can communicate up to five kilometres, but of course that's under ideal conditions and with a proper antenna. Speaking of antennas, you will need one for this board to work, and you can make your own with a small piece of wire, or you can buy one and use the on-board connector. →

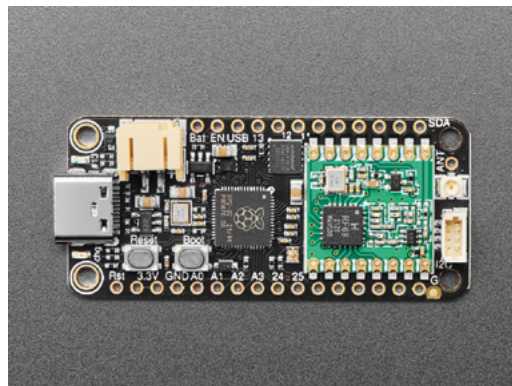

VERDICT

Adafruit Feather
RP2040 RFM69
Packet Radio

A good low-cost
radio and micro.

9/10

Spring is here! Time to deploy the sensors!

BEST OF BREED



Enviro Grow (Pico W Aboard)

PIMORONI ◆ \$51 | hsmag.cc/EnviroGrow

And how can we not cover the Enviro Grow systems by Pimoroni when talking about remote sensing and gardening? In a previous Best of Breed, I reviewed the Grow Kit, and no surprise, it was great. Well, now there is the Enviro Grow kit with a Raspberry Pi Pico on-board, featuring lots of accessories to get you started.

The kit includes the main Enviro Grow board with the Raspberry Pi Pico on the back. The board also includes an on-board BME280 temperature, pressure, humidity sensor, a Piezo buzzer, and a light and proximity sensor. And that's just the beginning of what's included in the kit – you also get three moisture sensors, three mini submersible pumps, a battery pack, batteries, and a bunch of other parts to get a fully automatic watering system up and running. It's a great kit for a great price. Head over to the Pimoroni site to learn more. □

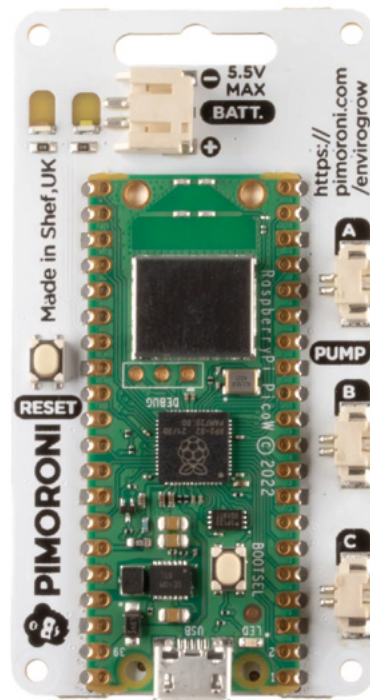

Left ◆
Get your plants to water themselves

VERDICT

Enviro Grow
(Pico W Aboard)

Environmental sensing with a Pico!

10 / 10

THE OFFICIAL Raspberry Pi Beginner's Guide

The only guide you
need to get started
with Raspberry Pi

Inside:

- Learn how to set up your Raspberry Pi, install an operating system, and start using it
- Follow step-by-step guides to code your own animations and games, using both the Scratch 3 and Python languages
- Create amazing projects by connecting electronic components to Raspberry Pi's GPIO pins

Plus much, much more!

£10 with **FREE**
worldwide delivery

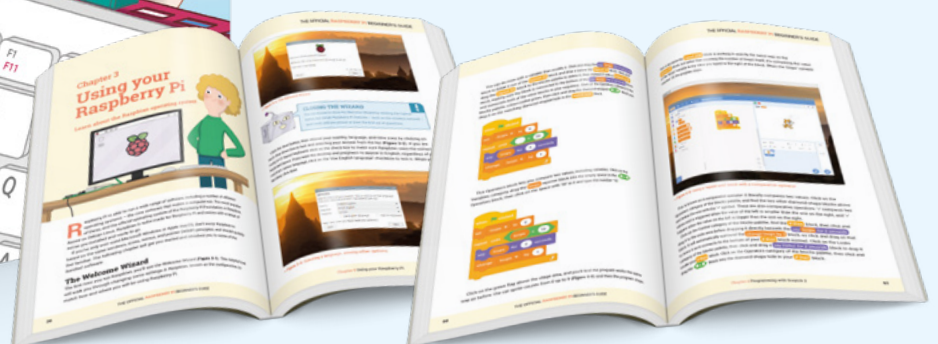
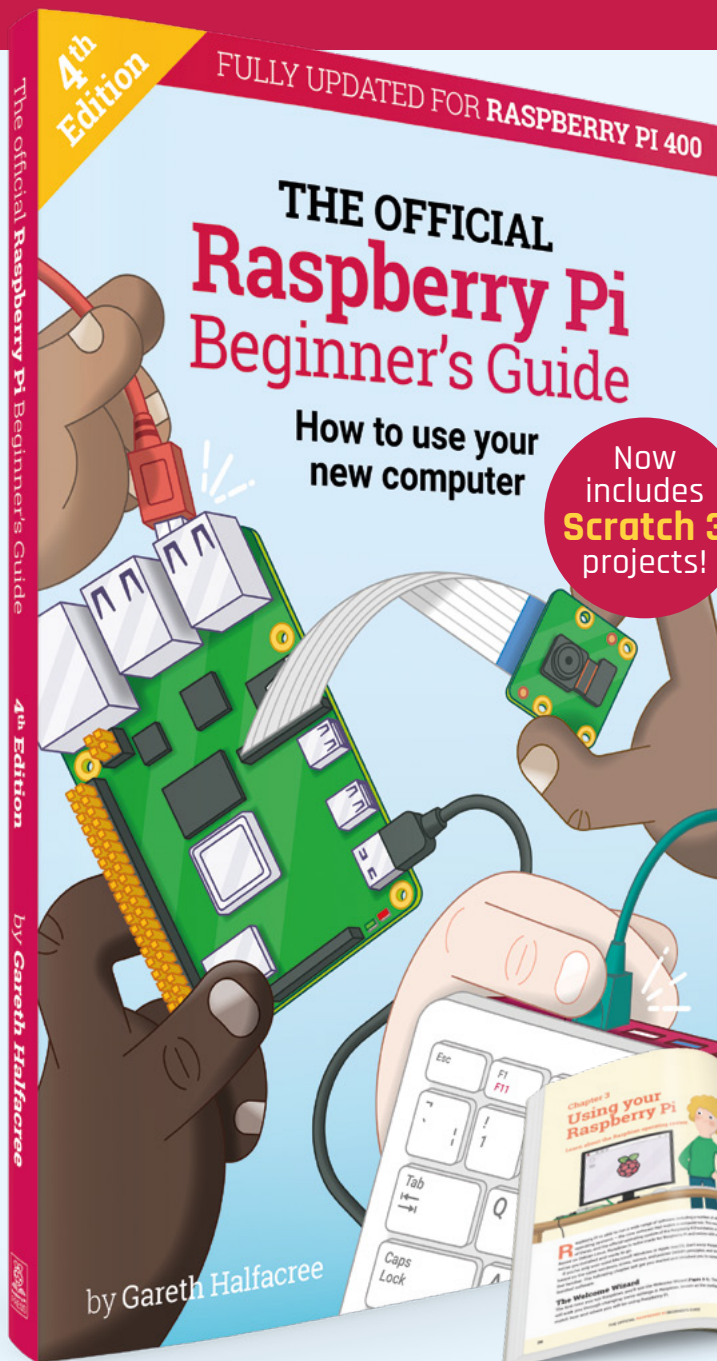

Buy online: magpi.cc/BGbook

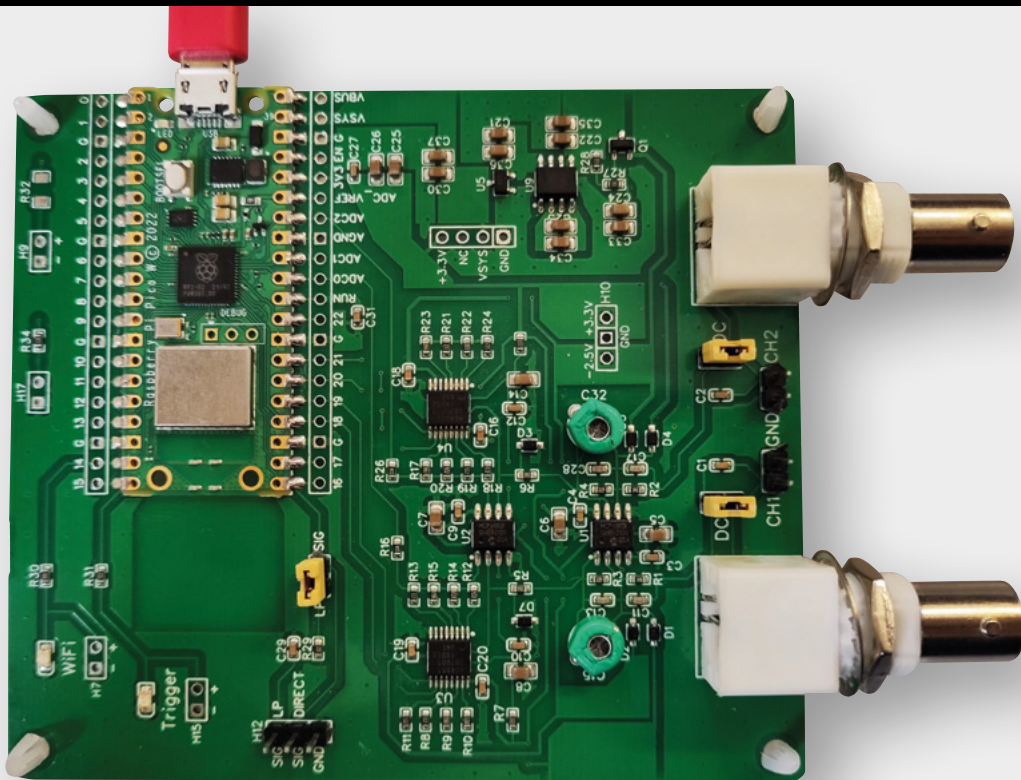

DSO-500K oscilloscope

Pico W on signal monitoring duty

FHDM TECH ◆ \$33.50 | hsmag.cc/dso-500k

By Ben Everard

 @ben_everard

Oscilloscopes are, at heart, very simple tools. They take a voltage and use that to display a point on a screen, usually, in a time-based graph. That's really all it takes to be an oscilloscope. However, underneath this is a huge web of complexity.

The first bit of complexity is the limits on the signal that it can display – the two main limits being voltage and frequency. For many users, voltage isn't particularly limiting. Many modern circuits only use fairly low voltages, and almost any oscilloscope can handle these. Frequency, though, is more of a problem.

If you're trying to debug a waveform, you need a sample frequency higher than the waveform because you need to see how the waveform is structured, so

you want to have multiple samples per wave. How many samples per wave depends on exactly what you're trying to see. This is a bit of a problem because, at very high speeds, electronics become challenging. Not only does the scope's processor have to be able to read and process the data as it comes in very fast, but the analogue electronics that sit in front of the analogue-to-digital converter (ADC) also have to handle the signal without introducing noise, which would render the reading inaccurate. The faster the data rate, the harder these two problems are. These two limits are slightly different, and the oscilloscope's data sheets should show them separately. The samples per second (usually given as MS/s or GS/s) is the number of samples the processor can read. The bandwidth is the maximum frequency the analogue circuit can handle.

Typically, there will be more than one input as well. Two and four are the most common options.

There are a bunch of other things that a modern oscilloscope should do to help you work out what a signal is showing. For example, adding two inputs together, or integrating a signal.

With all this in mind, let's take a look at the DSO-500K oscilloscope by FHD Tech.

500K refers to the number of samples per second the scope can take (this is combined on both channels, so if you're using both, it's 250,000 per channel, per second). The bandwidth is 150kHz, so any signals over this frequency may be distorted or filtered out.

To put these numbers in context, the limit on human hearing is about 20kHz, so any audio frequencies will be well within its range.

However, even the slowest 'standard' mode I2C is 100kbps, so you'd struggle to accurately see the waveforms of these signals. However, this device also has a 'logic analyser' mode in which it only detects the logical state of a connection. In this mode, it can do 20MS/s. There's no protocol decoding for the logic analyser, but you can export the samples as a CSV file.

The scope can handle +/- 6V with regular probes or +/- 20V with 10x probes, although neither is included, so you'll need these in addition to the main board.

This oscilloscope doesn't have a user interface built in. Instead, you can connect to it over Wi-Fi or USB from a phone or tablet, and there's an Android or

iPhone app called 'Scopy' that displays the signal and lets you set various options. Obviously, this means that the size and quality of the screen is entirely dependent on the device you hook it up to.

The interface provides most of the basic features you'd expect of an oscilloscope, including YT, FFT, and XY modes, various triggering options, and measurement of signal properties such as Vmax, Vmin, frequency, and duty.

This decoupling of screen and back-end (along with the fact that the firmware is open-source) means that you can also build your own back-end. The ADC is that of a Raspberry Pi Pico W, and you can flash the firmware onto this. The analogue interface can be as big or small as needed. In some cases, you might just be able to connect directly to the ADC pins. In other cases, you might need some protection circuitry. The Scopy app has a free version, but the premium version is bundled with the DSO-500K.

This is a budget and fairly low-speed oscilloscope. For audio work and similar speed signals, it can work great, but anything faster is going to cause problems. The logic analyser feature is interesting, but without the ability to decode protocols, it's a bit limited compared to other options. The standout feature of this, for us, is the openness of the platform. The ability to build your own hardware to work with the front-end means that there's a wide scope for hacking and building your own debug hardware. □

“ The limit on human hearing is about 20kHz, so any audio frequencies will be well within its range ”



Left ♦ The user interface is much like a traditional oscilloscope

VERDICT

A bit slow, but with excellent hacking potential.

9/10

CROWDFUNDING NOW

Crowdfunding SkySurfer

Take to the skies

From \$1698 | hsmag.cc/skysurfer | Delivery: April 2024

It's 2023, where's my hoverboard? Here. It's here. Hunter Kowald is crowdfunding the next phase of what he calls a SkySurfer. It's basically an octocopter that you can stand on.

Now admittedly, it takes a special kind of person to try and stand on what is essentially an upturned blender (OK, eight upturned blenders). It takes an even special-er person to stand on a first-generation crowdfunding version. And an even more special person to buy the first version as a DIY kit and try to build it themselves.

Is it safe? Maybe. We have no idea, and we don't have a spare \$54,000 to find out (\$10,000 of this is a down payment during the crowdfunding campaign, and the rest is due on delivery).

According to the manufacturers, it can carry 500 lbs (227kg), and can go at up to 65mph for 20 minutes. We suspect that it can't do all three of these at the same time, but that puts the range at somewhere around 20 miles. Even if travelling at this speed cuts the battery life by half, that still means you could get ten miles out of a single charge – that puts this in the commuter range for many people. We suspect that your local aviation authority may have some concerns about letting you do this, but is this the transport of the future, or just a niche product that will swiftly move from futuristic crowdfunder to side note in the history books? □

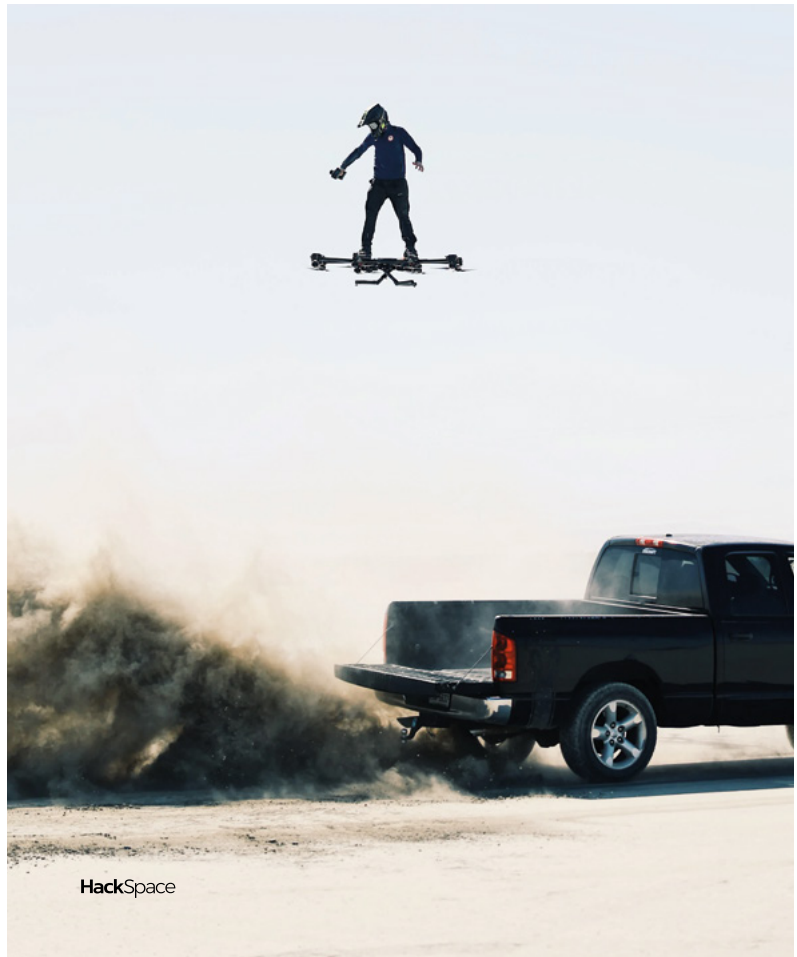



BUYER BEWARE

When backing a crowdfunding campaign, you are not purchasing a finished product, but supporting a project working on something new. There is a very real chance that the product will never ship and you'll lose your money. It's a great way to support projects you like and get some cheap hardware in the process, but if you use it purely as a chance to snag cheap stuff, you may find that you get burned.

issue

#68

ON SALE
22 JUNE

Photography
HACKS

ALSO

- 3D PRINTING
- CIRCUITPYTHON
- RASPBERRY PI
- LASER CUTTING

DON'T MISS OUT

hsmag.cc/subscribe

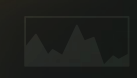

Next month



Farming

Welcome to the Prusa print farm. Here, in a factory not too far from the Czech National Museum of Technology, the current wave of the industrial revolution is happening right now.

The farm consists of over 700 printers, all printing parts to make other 3D printers. It is, as Josef Průša puts it, “self-replication at scale... to show our customers where it can be used”. Or, as it’s called in the software industry, “eating one’s own dog food”. At present, these are mostly Prusa MK3 printers – the same model that you can buy yourself and use at home, and we find that simultaneously comforting and exciting.

PiKVM

Manage your servers or workstations remotely

A **cost-effective** solution for data-centers, IT departments or remote machines!



PiKVM HAT
for DIY and custom projects



Pre-Assembled version

- Real-time clock with rechargeable super capacitor
- OLED Display
- Bootable virtual CD-ROM & flash drive
- Serial console
- Open-source API & integration
- Open-source software
- Bootable virtual CD-ROM

Available at the main Raspberry Pi resellers



Reseller suggestions and inquiries:
wholesale@hipi.io